



BERGES

Operating Instructions



Verstellgetriebe VG
Nr. 40.001.00.0 Rev.8
27.01.2021

VARIABLE SPEED UNITS VG

System overview

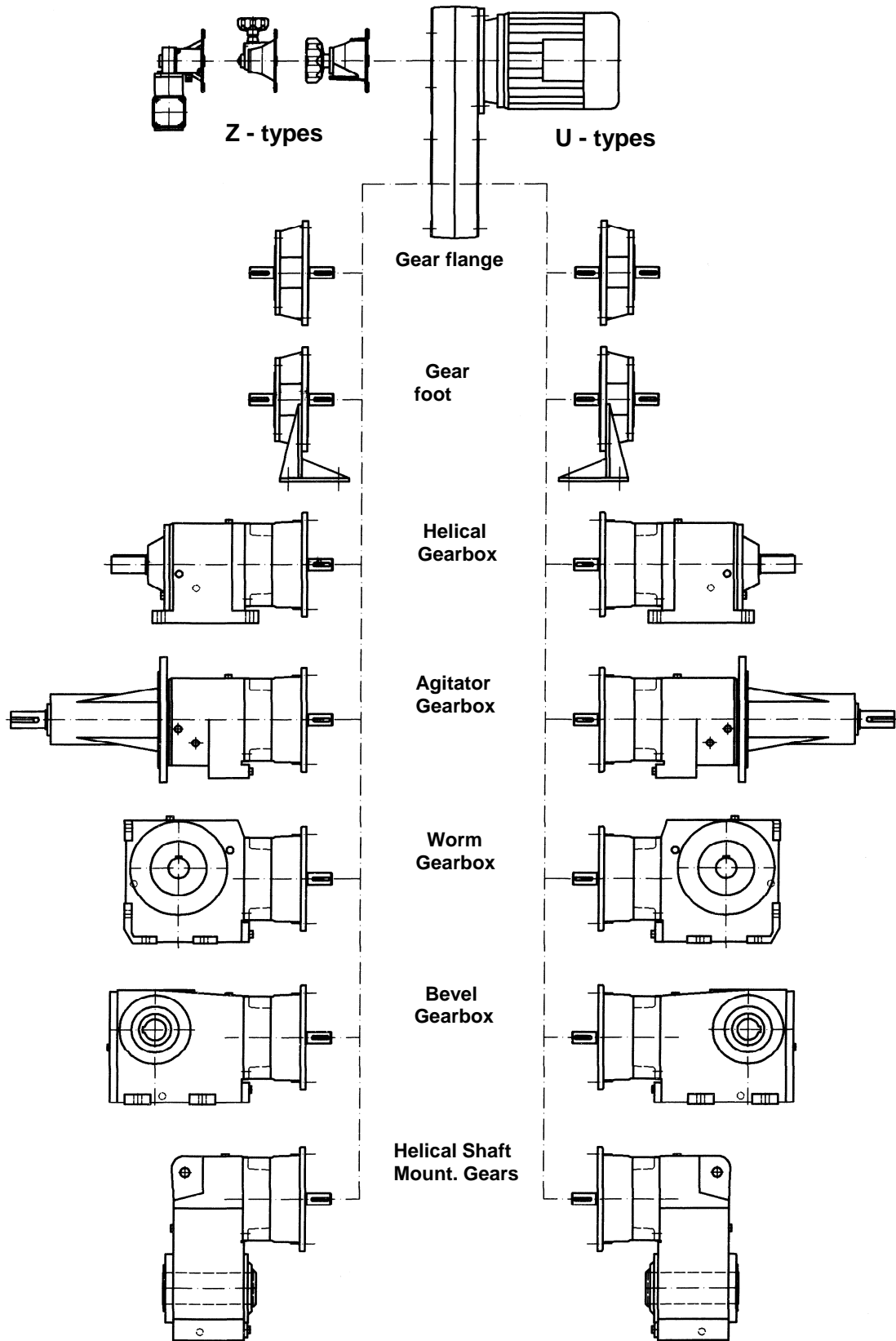

	System overview	2
	Contents	3
1	General	4
1.1	How to use the Operating Instructions	4
1.1.1	Terms used	4
1.2	Delivery	4
1.3	BERGES Variable speed units VG	5
1.3.1	Identification	5
1.3.2	Use as intended	5
1.3.3	Legal provisions	5/6
2	Safety information	7
2.1	Persons responsible for safety	7
2.2	General safety information	8
2.3	Conventions used for safety information	9
3	Technical data	10
3.1	Product characteristics	10
3.1.1	Mechanical construction	10
3.1.2	Functioning	11
3.2	Operating conditions	11
3.3	Version for explosive area	11
	Figures 3 and 4	12
	Figures 5 and 6	13
4	Installation	14
4.1	Incoming inspection and transportation	14
4.2	Storage	14
4.3	Assembly	14
4.3.1	Preparations after a long storage period	14
4.3.2	General information about the assembly of variable speed units VG	14/15
4.4	Electrical connection	15
4.4.1	Connection of the main motor	15
4.4.2	Connection of the servo motor (electrical remote control)	16
4.4.3	Connection of the rev-counter	17
5	Commissioning	18
5.1	Before commissioning	18
5.2	During operation	18
5.3	Placing out of operating	19
5.4	Operation	19
6	Maintenance and Servicing	20
6.1	Servicing intervals	20
6.1.1.	Checking the wide V-belt	
6.2	Maintenance work	21
6.2.1	Changing the Wide V-belt	21-22
6.2.2	Setting the output speed	22-24
6.2.3	Changing the variable-speed pulleys	25-26
6.2.4	General maintenance	26
7	Troubleshooting	27
8	Stocking spare parts, after-sales servicing addresses	28
8.1	Spares inventory	28
8.2	After-sales servicing addresses and addresses for spare parts	28
9	Conformity declaration	29
10	Power- and Torque Curves	Annex

1 General

1.1 How to use these Operating Instructions

- The Operating Instructions are a part of the delivery of the BERGES variable speed units VG. They contain safety information that must be observed. Consequently, always keep the Operating Instructions near to the variable speed units!
- Only with the knowledge contained in this operating instructions it is possible to achieve a safe, trouble-free operation by avoiding operation errors and incorrect use of the variable speed units.
It is thus important that the Operating Instructions have been read and understood by those responsible for transportation, assembly, installation, operation and servicing and that all aspects contained therein be followed.
No liability can be accepted for damages and operating malfunctions caused by failure to observe the operating and maintenance instructions!
- Please contact our plant should you have any technical questions:

BERGES Antriebstechnik GmbH & Co.KG
Postfach 1140
Industriestrasse 13
D - 51709 Marienheide
Tel. : 0 22 64 / 17 - 0
Fax. : 0 22 64 / 17 123
E - mail : vertrieb@berges.de

1.1.1 Terms used

- BERGES variable speed units are referred to as *VG* for short.
- BERGES Operating Instructions are referred to as *Op. Inst. for short*
- BERGES Assembly units are referred to as *RGAE* for short

1.2 Scope of delivery

- The *VG* are assembled individually on the basis of a modular system.
Please refer to the related accompanying documents for the scope of delivery.
- After receipt of the consignment, please check immediately that the scope of delivery corresponds to the accompanying documents.

1.3 BERGES VG units

1.3.1 Labelling

- BERGES VG units are uniquely identified by the information on the rating plate.

- When used in hazardous areas:

 II 2 G h IIB T4 Gb
 II 2 D h IIIC 135°C Db

- Manufacturer:**
 Berges Antriebstechnik GmbH & Co. KG
 Industriestrasse 13
 D - 51709 Marienheide
 Phone (02264) 17- 0
 Fax: (02264) 17 123
 email: vertrieb@berges.de

1.3.2 Use as intended

- BERGES - VG
 - are intended for use in the commercial sector in machinery and equipment
 - may be used only for the technical parameters ordered and confirmed
 - may be operated only under the operating conditions prescribed in these Operating Instructions.
 - may not be operated outside of the stipulated performance limits
- Differing operating conditions will require new contractual agreements.
- Within the scope of the machine directive 2006/42/EG the commissioning of the VG unit is prohibited unless it has been stated that the conformity of the final product complies with the requirements set out in these directives.

1.3.3 Legal provisions

Liability

- The drives described in the *Op. Inst.* and the information, data and instructions provided comply with the state of the art at the date of printing.
 No claims with respect to VG already delivered may be asserted from the information, illustrations and descriptions.
- We are unable to assume liability for damages and malfunctions resulting from
 - improper use
 - unauthorized modifications to the VG
 - incorrect work carried out on and with the VG
 - operating errors
 - non-compliance with the Operating Instructions

- We reserve the right to make modifications to the drives in the interest of technical improvement and in order to enhance safety.
- Amendments or supplements to the *Op. Inst.* may be made solely by us; violation of this clause will result in all warranty claims being null and void.
- Copyright to these *Op. Inst.* is retained by:

BERGES Antriebstechnik GmbH & Co. KG

- **Note:**
Please refer to the other supplied Operating Instructions for reduction gears, motors and auxiliary equipment such as remote speed indicators and electrical remote controls
- **Terms of warranty**
Please refer to the Terms of Sale and Delivery of BERGES Antriebstechnik GmbH & Co.KG, Marienheide.
- Warranty claims must be reported immediately after detecting defects or faults to BERGES Antriebstechnik GmbH & Co. KG, Marienheide
- Warranty shall become null and void in all cases in which no liability claims can be asserted either.

2 Safety Information

2.1 Persons responsible for safety

- **User**

The user is any natural person or legal entity who or which uses the VG or on whose behalf/on behalf of which the VG are used.

The user resp. his Security Officer is responsible for ensuring

- that all relevant regulations, instructions and laws are complied with.
- that only qualified personnel work on and with the VG.
- that the personnel has available the Operating Instructions when carrying out any corresponding work on and with the VG.
- that the personnel has read and understood the VG.
- that non-qualified personnel are forbidden to work on and with the VG.

- **Qualified personnel**

Qualified personnel are persons who, on the basis of their training, experience, instruction and knowledge of relevant standards and regulations, accident prevention and operating conditions, have been authorized by the person responsible for system safety to perform the relevant, required activities and who, when doing this, are able to recognise and avoid the possible risks and dangers.

2.2 General safety information

- Please contact BERGES Antriebstechnik GmbH & Co. KG should you have any questions or problems.
- The VG comply with the state of the art on the date of delivery and are always delivered in a safe operating condition.
- The VG may be used and operated only within the framework of the conditions stipulated in the Performance and Supply Contract (speeds, powers and torques, see annex).
- The VG pose risks and dangers to persons, to the VG themselves and to other valuables of the user if:
 - non-qualified personnel work on and with the VG or
 - the VG are used inappropriately.
- The VG must be planned such that they perform their function and cause no risk or danger to persons if they perform their function correctly after having been properly installed and if used as intended. This also applies to interworking thereof with the overall installation.
- The VG may be installed, placed into operation, serviced and, if necessary, re-paired only by authorized, trained and instructed qualified personnel. (see point 2.1 for definition of qualified personnel).
- Operate the VG only in proper working order.
- All work on the VG must be performed carefully with a view to *safety* and may only ever be carried out at 'standstill'. In this case, the drive must be locked to prevent 'unintentional switch-on' (e.g. by locking the key-operated switch or removing the fuses from the power supply). An information sign indicating that work is underway on the drive must be attached to the 'switch-on point'. The only exception is the setting of the output speeds (see 6.2.2.)
- Do not adjust the VG during standstill.
- Always follow the relevant regulations on work safety and environmental protection during transport, assembly, dismantling, operation, care and servicing.
- Rotating operating components such as couplings, gearwheels or belt drives must be protected by means of suitable guards to prevent accidental contact.
- The VG must be shut down immediately should changes, such as increased operating temperature or gear noises, occur during operation.
- When installing the VG in equipment or installations, the manufacturer of the equipment or installations is obliged to include the regulations, instructions and descriptions contained in these *Op. Inst.* in his own Operating Instructions.
- Retrofittings, modifications and changes of the VG are generally forbidden.

2.3 Conventions used for safety information



Signal word
Information text

- The pictogram identifies the type of danger
- The signal word identifies the severity of the danger
- The information text describes the danger and provides information on how to avoid the danger

Warning against personal injury

Pictograms used	Signal words	
<p>Warning of explosive atmospheres</p>	Danger!	Warns against directly imminent danger. Consequences if not followed: Death or very serious injury.
<p>Warning against hazardous electrical Voltage</p>		Warns against a possible very dangerous situation. Possible consequences if not followed: Death or very serious injury.
<p>Warning against a general danger</p>	Caution!	Warns against a possible very dangerous situation. Possible consequences if not followed: minor or slight injury.

Warning against damage to property

Pictograms used	Signal words	
	Stop!	Warns against possible damage to property. Possible consequences if not followed: Damage to the VG or it's environment



Other information

Pictograms used	Signal words	
	Tip!	Identifies a general, useful tip. If you follow this tip, this will make your work with the VG easier.

3 Technical Data

- The most important technical data are specified on the rating plates. These data and the contractual agreements for the drives stipulate the limits for the use as intended.
- On the VG with reduction gearbox and motor , three rating plates are normally attached. One rating plate is attached to the motor, one is attached to the gearbox and one attached to the RGAE. On the VG with GFL or GTF two rating plates are attached, one on the motor and one on the RGAE.

 BERGES Antriebstechnik 51709 Marienheide - Tel. 02264/17-0		plate for non explosive area
Typ	<input type="text"/>	
KB-Nr.	<input type="text"/>	
Baujahr	<input type="text"/>	

 BERGES Antriebstechnik GmbH & Co.KG 51709 Marienheide Industriestr. 13		plate for explosive area	
Typ	<input type="text"/>		n_2/min^{-1}
RGAE	CE  II 2 G h IIB T4 Gb		T_2/Nm
Nr	CE  II 2 D h IIIE 135° Db		n_3/min^{-1}
BJ	<input type="text"/>		T_3/Nm

Type= for example RGAE 4/210

No. = Order number

n_2 = speeds of the RGAE

T_2 = Torques of the RGAE

n_3 = Speeds of the VG

T_3 = Speeds of the VG

3.1 Product characteristics

3.1.1 Mechanical construction

BERGES VG are constructed on the basis of a modular system. They consist of the following components:

- BERGES assembly units RGAE
- Output flanges or output feet GFL or GTF
- Gear boxes (helical -, worm -, bevel - and helical shaft mount. Gearboxes)
- Three-phase motors to IEC standard
- Speed controls: Spindle control SS, angled control WS, hydraulic control HSG or electrical remote control EV or EFV.
- Speed indication units



Caution ! Operation of the variable speed geared motors only admissible at the provided mains frequency

3.1.2 Mode of operation

(see Figures 3 and 4, Page 12)

- The three-phase motor (Item 8) drives the mechanically adjustable regulation pulley R (Item 1). This drives the spring-loaded spring pulley F (Item 2) which is arranged on the drive shaft of the gear flange *GFL* (Item 7 resp. Item 7.1, Figure 5, Page 13) or the drive shaft of the reduction gear (Item 5), via the wide V-belt (Item 6). Depending on gearbox type, the gearbox is attached either directly to one of the two housing halves (Item 3 / Item 4) or using the gearbox flange *GFL* resp. gearbox foot *GTF* (Item 7.1 resp. 7.2)
- The rotational speed is adjusted by the adjustment device (Items 10, 11, 12) by shifting the moving running surface of the mechanically adjustable pulley R in axial direction by turning the handwheel resp. operating the remote control motor. The speed indication (option) is provided by the position indicator in the scaled handwheel or electrically by means of a pulse generator and indication unit.

3.2 Operating conditions

- The operating conditions, such as temperature and installation altitudes, are defined by the drive motor, the *RGAE* and the reduction gearbox (see the relevant Operating Instruction). The max. permitted operating temperature of the variable speed drive *VG* is 60°C at normal operation - to be measured at the outside of the *VG* housing at 20°C ambient temperature.

The permissible ambient temperature is -20°C to +40°C.

3.3 Version for explosive area

- To achieve protection type “Constructional safety” for mechanical devices – for the purposes of directive 2014/34/EU – a protection angle is installed on the ventilation slot of the adjustment control. The protection angle prevents penetration by smaller components and thus also the occurrence of mechanical generated sparks.

Figure 3 BERGES Variable Speed Gear VG mounting position U

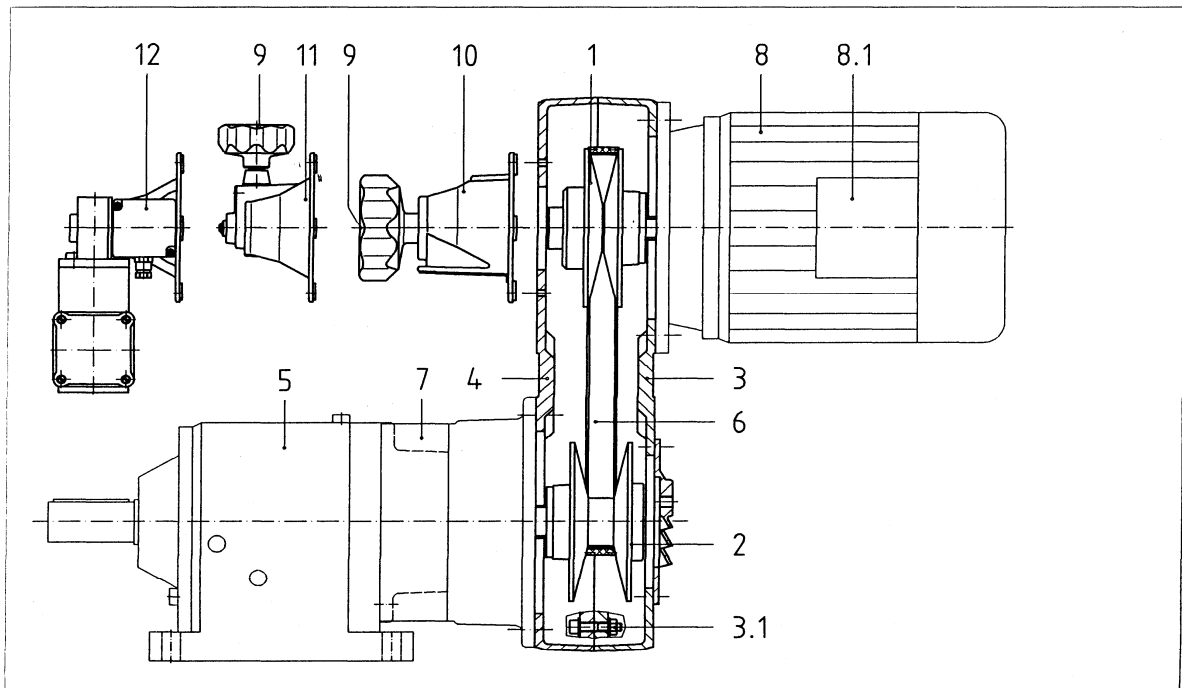
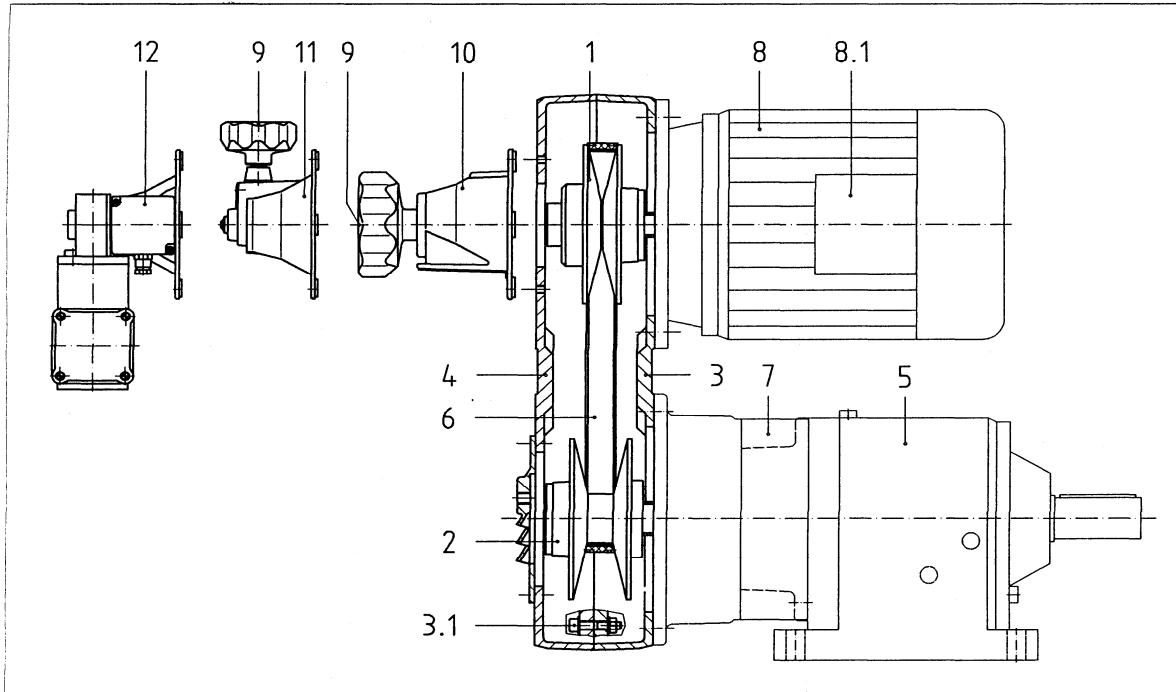

Figure.4 BERGES Variable Speed Gear VG, mounting position Z

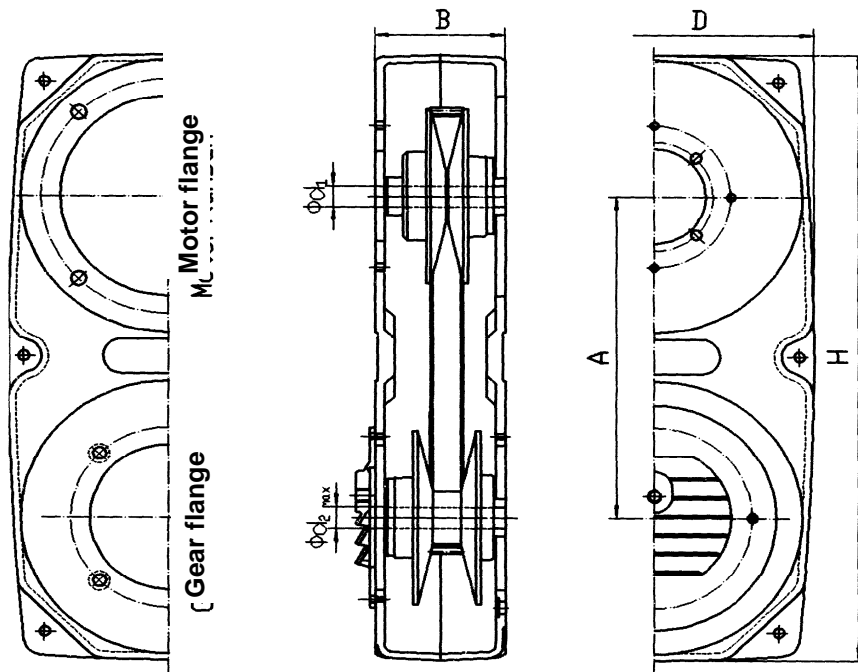

Figure 5 BERGES ASSEMBLY UNITS *RGAE*

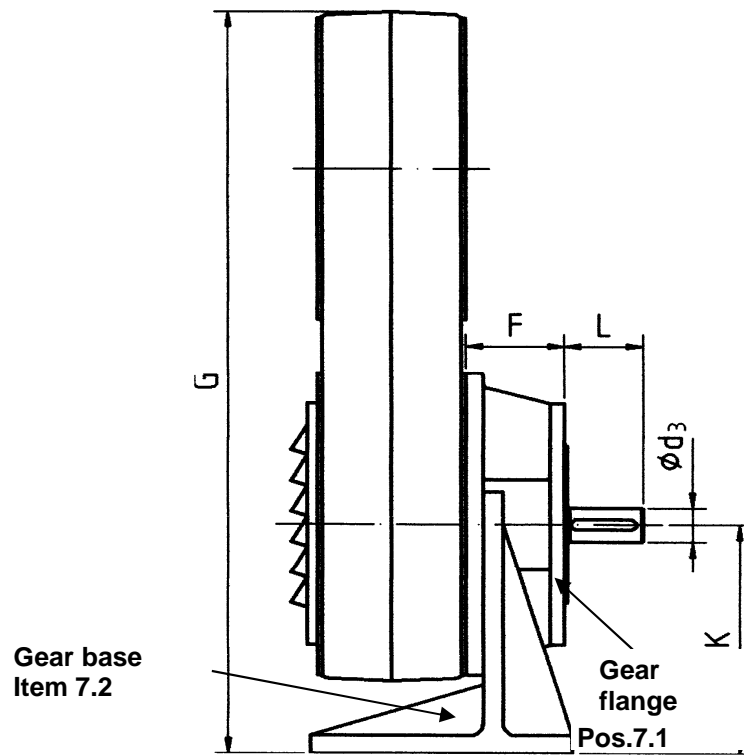

Figure 6 BERGES ASSEMBLY UNITS *RGAE* (with base and flange)

4 Installation

4.1 Incoming inspection and transportation

- The consignment must be examined immediately on arrival for completeness and transport damage.

Caution !

Use only slinging equipment with a adequate load-carrying capacity to transport the drive. Ensure that the equipment is correctly secured. Avoid shocks.



Equipment in **Z**-shape design is not stable! Ensure that such equipment is appropriately supported.

4.2 Storage

- Drives which are not being installed immediately must be covered and stored in dry rooms not subject to major temperature differences and in the position of normal use.



Stop!

Do not store drives in the open air.

- Lightly grease exposed case surfaces of the reduction gearboxes and shaft ends.
- If the equipment is to be stored for longer than six months, remove the wide V-belt.
- If the equipment is to be stored for longer than six months, inspect the preservation and renew it if necessary.

4.3 Assembly

4.3.1 Preparations after a long storage period

- If the equipment has been stored for a long period, the shaft ends and case surfaces of the reduction gearbox must be cleaned to remove all traces of corrosion inhibitor.

4.3.2 General information on installation of variable speed drives VG

- Always follow the safety information in Chapter 2 when starting installation.
 - Disconnect the machine from the electrical mains and ensure that the drive cannot operate and that all machine movements are prevented.
 - Check that the VG are in proper working order. Never operate damaged VG.
 - Check the assignment of the drive function to the machine function and the direction of rotation.
- As early as the planning stage, ensure that the space provided is adequate for the drive thus to be able to perform installation, care and servicing work unhindered.

Installation

- The mounting areas on which the VG are to be fitted must be level, torsionally resistant and free of vibration. (levelness $\leq 0,1$ mm)
- Align the VG on the mounting surface precisely in line with the machine shaft to be driven.
- Ensure that the units are mounted free of stresses and strain thus avoiding additional loading.
- Compensate for minor irregularities (alignment and angular errors) by using suitable, flexible couplings.
- Take appropriate measures to absorb reaction torques.
- Lock mounting points for accessories and attachments and mounting points for the VG themselves appropriately to protect against self-loosening.



Caution !

Prolonged exposure to sunshine may lead to overheating of the drive. Provide corresponding guards. No welding work may be carried out on the drive and the drives may not be used as grounding points for welding work.



The variable speed gears may be used in the designated mounting position, only

- Use suitable mounting tools or extractors to perform installation and dismantling work on drive and output elements such as belt pulleys, sprocket wheels, running wheels or gear wheels and couplings etc. on the gear shafts. *On no account may the part to be fitted be forced onto the shaft by hammering.*



Stop!

The lubricant filling quantity of the gears is determined by the installation position. Always comply with the installation position specified on the rating plate in order to avoid gear damage.



Caution !

The VG of Z-design are not stable and must thus be supported appropriately for installation - until securely attached.

4.4 Electrical connection



Danger !

Electrical connection work must be carried out by a qualified electrician.



The variable speed gear must be suitably earthed.

4.4.1 Connection the main motor

- The main motor of the VG must be connected in accordance with the information in the terminal box of the motor and in the separate Motor Operating Instructions. Always note the technical data on the motor rating plate (Item 8.1). (see also Figure 3 and Figure 4 , Page 12).

4.4.2 Connection of the electrical remote control motor



Stop!

The motor of the electrical remote control may be operated only with the main motor operating.

- 1. Connect the motor in accordance with the circuit diagram (Figure 7).
- 2. Check the direction of rotation in jog mode:
 - Briefly press button S1; the operating pin must move towards the bolt-on flange.
 - Briefly press button S2; the operating pin must move in the opposite direction.
 - If the directions are incorrect, reverse the polarity of the motor.
- 3. Checking the function of the limit switches:
 - Actuate limit switch S3 ($n_{2 \max}$) and briefly press button S1.
 - Actuate limit switch S4 ($n_{2 \min}$) and briefly press button S2.
 - The operating pin may not move in either of the two cases.

Figure 7
Connect.diagr.for electr.remote control

F1	Fuse
K1, K2	Combined switching contactor for phase reversal (clockwise or counter clockwise rotation of the motor)
M1	Adjustment motor
Q1	Master switch
Q2	Motor protection switch
S1	Pushbutton switch "Faster"
S2	Pushbutton switch "Slower"
S3	Limit switch (upper speed limitation)
S4	Limit switch (lower speed limitation)
1	Drive motor (main motor)
2	Control phase of drive motor
3	faster
4	slower

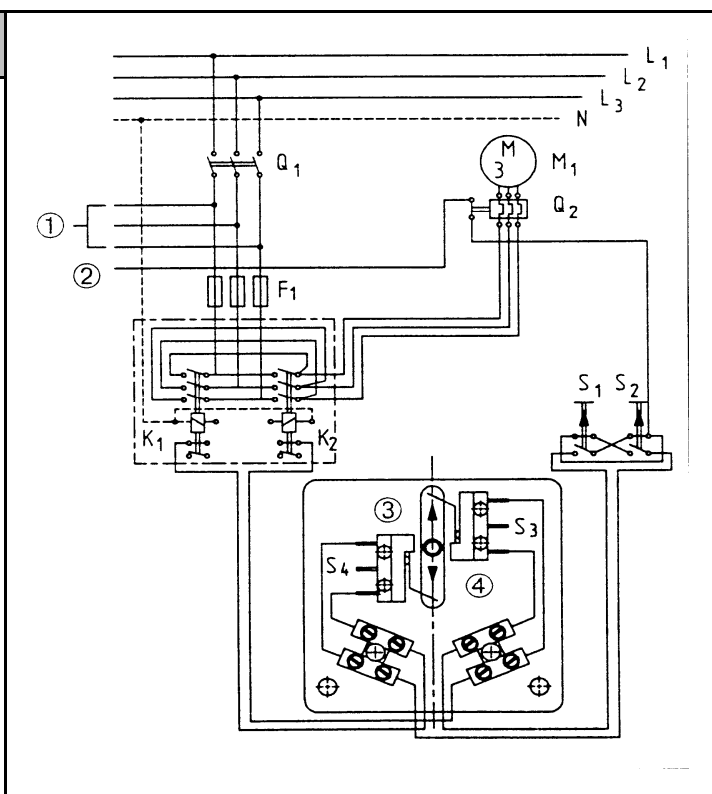

4.4.3 Connection of the rev-counter

- The electrical rev-counter is an option and is supplied with a connection cable. The connection is specific to the application - if using an indicator provided by the customer - or in accordance with the regulations for the BERGES indicators.

- **Pulse encoder**

The rotational speed is measured without physical contact using a rotating perforated disc which simultaneously serves to secure the spring pulley and a stationary pulse encoder.

The pulse encoder generates a digital signal in conjunction with a NAMUR input.

Suitable BERGES indicators:

- Digital indicator unit **MDA 26**
- for supply voltage 230V-AC
- If the drive is used in hazardous areas an isolating switching amplifier between indicator and drive has to be fitted.



Technical Data pulse encoder:	
Housing	High-grade steel, stainless
Connection - cable	5m PVC-cable 2x 0,34mm ²
Contr. circuits	Namur
Rated voltage	8,2V
Sensing dist.	0.....2,0 mm
EMV to	EN 60947 - 5 - 2

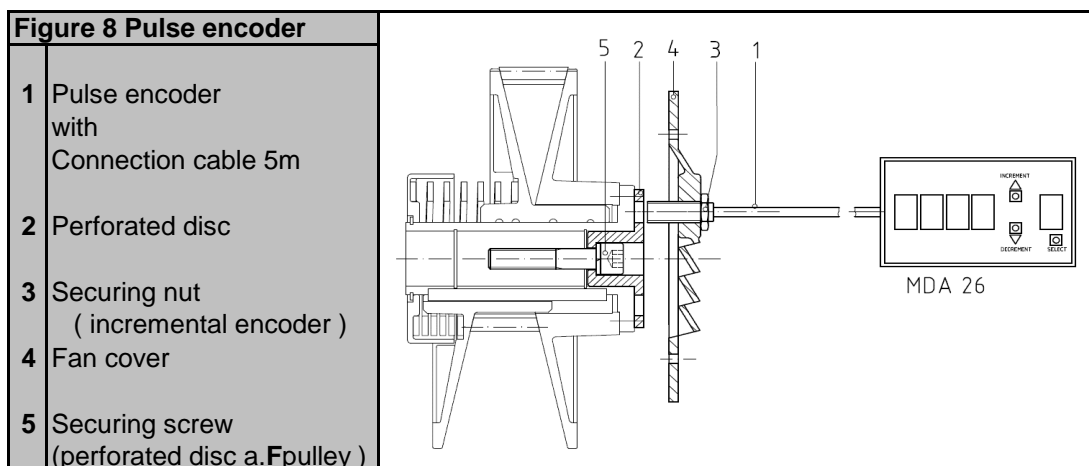

- 1. Insert the collar of the perforated disc (Item 2) into the bore of the spring pulley and secure it with the securing screw (Item 5) in the output shaft.
- 2. Screw the pulse encoder (Item 1) into the ventilation cover (Item 4).
- 3. Set the measuring gap: Screw the pulse encoder (Item 1) fully against the perforated disc (Item 2), turn it back two turns (sensing distance approx. 2 mm) and secure with the nut (Item 3) against the ventilation cover (Item 4).



Caution ! Ensure that the pulse encoder (Item 1) is not screwed into a bore in the perforated disc.

- 4. Install the indicator and connect it as shown in the connection diagram.
- 5. Adjust the reading: (see separate Operating Instructions supplied with the indicator).

5 Commissioning



Stop!

The drive may be commissioned only by trained personnel.

Fit the wide V - belt beforehand if commissioning after six *months* (see also Point 4.2, Page 14).

5.1 Before commissioning



Caution !

Secure the drive to prevent the power supply being switched on unintentionally.
(Attach a corresponding information sign to the switch-on point)

Please check the following:

- Is the drive properly secured mechanically ?
(Check securing bolts for firm attachment and retighten it if necessary)
- Are the electrical connections ok ? (Check the direction of rotation before commissioning - if necessary - and reverse two phases if necessary)
- On gearboxes with vent:
Has the travel plug been removed from the ventilation screw ?
(Remove travel plug if necessary.)

5.2 During Operation

- Conduct regular checks and inspections during operation. Watch out particularly for unusual noises and/or high temperatures, (exceeding 60°C - see point 3.2), leaks, loose securing elements and the condition of the electrical cables.
- Should malfunctions or faults ever occur, please consult the troubleshooting table in Chapter 7. If the fault or malfunction can still not be remedied, please inform BERGES Antriebstechnik GmbH & Co. KG.



Stop!

Never adjust the speed at standstill !
Adjusting the speed at standstill damages the VG .

5.3 Placing out of operation

- Place the drive out of operation by switching off the drive assembly.



Caution !

Lock the drive to prevent the power supply being switched on unintentionally. Attach a corresponding information sign to the switch-on point.

- If the drive is placed out of operation for a longer period, operate the drive weekly for a short time. If the drive is placed out of operation for longer than six months, remove the wide V-belt. (see also point 4.2, page 14).

5.4 Operation

- Check the VG for the following during operation:
 - excessive operating temperature
 - changed running and gearbox noises

Caution !

If irregularities such as those described above are detected during operation, shut down the drive assembly immediately. The cause of the fault can then be determined using the fault-finding table (see Chapter 7 - Troubleshooting).



Possible faults and malfunctions, their causes and suggestions for remedying the faults are contained in the "Fault-finding table".

If you are unable to establish the cause of the fault or if the fault cannot be remedied using your resources, please contact Berges Antriebstechnik GmbH & Co. KG.

- Run the VG only within its performance limits.

**Tip!**

To increase the life of the VG run the whole speed range at least once a week.

6 Servicing and maintenance

6.1 Servicing intervals



Stop!

Please adhere to the servicing intervals which are listed below.



Avoid damages to the variable speed units *VG* and check regularly for possible damages.

Time interval	What to do?
every 3000 operat.hours at least six-monthly	<ul style="list-style-type: none"> ▪ Check the V-belt (siehe 6.1.1) ▪ Clean the ventilation openings ▪ Check the interior of the <i>VG</i> for dust and dirt deposits.
every 6000 operat.hours	<ul style="list-style-type: none"> ▪ Change the wide V-belt (see 6.2.1)
every 20000 operat.hours	<ul style="list-style-type: none"> ▪ Change the variable speed pulleys (see 6.2.3)

6.1.1 Check of wide V-belt

Should you answer one of the following verification questions with "yes" the V-belt must be changed.

Type of inspection	Check on the <i>VG</i>
Functional test	<ul style="list-style-type: none"> ▪ Is there a high noise development ? ▪ Has the max. speed dropped down by more than 10 %? ▪ Are there speed fluctuations?
Sichtprüfung	<ul style="list-style-type: none"> ▪ Is there much abrasive dust at the ventilation openings on the housing? ▪ Are the belt flanks frayed? ▪ Does the belt show cracks between its teeth?

6.2 Servicing work

6.2.1 Breitkeilriemen wechseln



Stop!

Should it be necessary to replace the belt only original BERGES wide V-belts shall be used!

Dismantling procedure for U version (see also fig. 3, page 12)

1. Switch on the drive and accelerate it to maximum speed. Then switch off the drive and disconnect it from the mains.
2. Undo the screwed housing connections (Item 3.1), (4, 6 or 8 screws - depending on the drive size) and remove the housing half (item 4).
3. Fully open the control pulley R (item 1) and remove the V-belt (item 6) over the anterior edge of the pulley R (item 1) and by turning the control and the spring pulley (by hand).

Dismantling procedure for Z-version (see also fig. 4, page 12)

1. Switch on the drive and accelerate it to maximum speed. Then switch off the drive and disconnect it from the mains.
2. Undo the screwed housing connections (Item 3.1), (4, 6 or 8 screws - depending on the drive size) and separate the housing half (item 3) and the housing half (item 4) from each other by supporting the three-phase motor, (item 8) thus it is possible to remove the V-belt (item 6) from the control pulley R (item 1).

Assembly of U- and Z-version (see also fig. 3 and 4, page 12)

1. First fit the new wide V-belt into the spring-loaded spring pulley F(Item 2) and thread it up by hand and then fit it into the fully-open mechanically adjustable variable-Speed pulley R (Item 1). Turn the drive by hand until the belt is taut.
2. Bolt the halves of the housing (Items 3 und 4) back together (4, 6 or 8 bolted connections)
3. Conduct a trial run. When doing this, check the speed limits and the setting of the speed indicators using a hand-held rev-counter. It may be necessary to readjust the setting owing to allowable wide V- belt length tolerances (see Chapter 6.2.2, Page 22 - 24).



Tip! U version, Figure 9

On sizes *RGAE*4 to 9, the spring pulley F (Item 2) can be opened by screwing a bolt into the main hub flange against spring pressure. The wide V-belt can then be fitted first into the open spring pulley F (Item 2) and then into the open variable speed pulley R (Item 1). Follow the reverse procedure when dismantling.

Abb.9 Spring Pulley F	
Pos. 1 only at size 4 - 9	
Necessary screw dimension: DIN 933	
Size 4/210	M5 x 45
Size 5/250	M5 x 55
Size 5/280	M6 x 70
Size 6/300	M8 x 70
Size 6/350	M8 x 70
Size 7/375	M8 x 80
Size 7/400	M8 x 80
Size 8/450	M12 x 90
Size 8/500	M16 x 90
Size 9/600	M20 x 100



Caution!

Always remove the bolt again after assembly and prior to placing into operation.

6.2.2 Setting the output speed

- The output speed limits n_{2max} und n_{2min} are preset at works
After changing the V-belt the speed range must be checked and if necessary the speed limits have to be re-adjusted.



Stop!

Never adjust the speed during standstill !
Adjusting the speed whilst standstill damages the VG.

Always ensure that the V-belt



- does not run on the base of the hub (clearly audible, whistling running noise)
- cannot move beyond the edges of the control and/or spring pulley.

Procedure in case of an electrical remote control (fig. 7)

1. Switch on the drive motor (pos. 8 - fig. 3 and 4, page 12)
2. First set the upper speed limit (n_{2max}):
 - Check the speed with the hand-held rev-counter and increase the speed to maximum speed with button S1
 - Slide the limit switch S3 against the operating pin until the operating pin can be heard to switch.
 - Firmly tighten the securing bolts of the limit switch.
3. Then set the lower speed limit in the same way (Button **S2** and limit switch **S4**)

Procedure in the case of spindle and angle adjustment (fig.10 und 11)

1. Switch on the drive motor (Pos. 8 - fig. 3 and 4, page 12)
2. Detach the bottom cover plate (item 4) of the adjustment device.
3. Adjust the drive with the handwheel (pos. 8) and the hand-held rev-counter to maximum speed
4. Adjust the nut (item 6) as end-limit.
5. Set the minimum speed in the same way with the nut (item 5).
6. Re-attach the cover plate (item 4)
7. Then, using the hand-held rev-counter, check that the reading of the position indicator (optional) at the handwheel corresponds to the actual speed value or the corresponding comparison value.



Caution! The pressure pot of the speed adjustment must always be in contact with the bearing ring. Pressure pot must not cause friction.

Adjustment of the position indicator (fig. 10 and 11)

1. Undo the setscrew (item 7) and remove the scale insert (item 9)
2. Turn the scale insert (item 9) until the reading corresponds to the actual value or the comparison value.
3. Re-insert the scale insert (item 9) into the handwheel and lock it with the setscrew (item 7).

Fig. 10 Spindle control SS

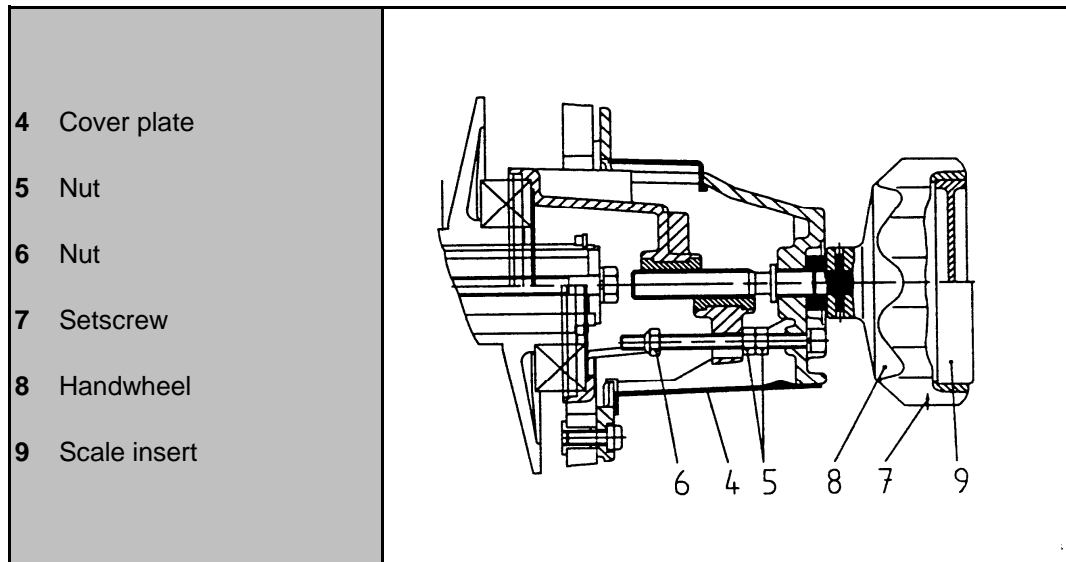
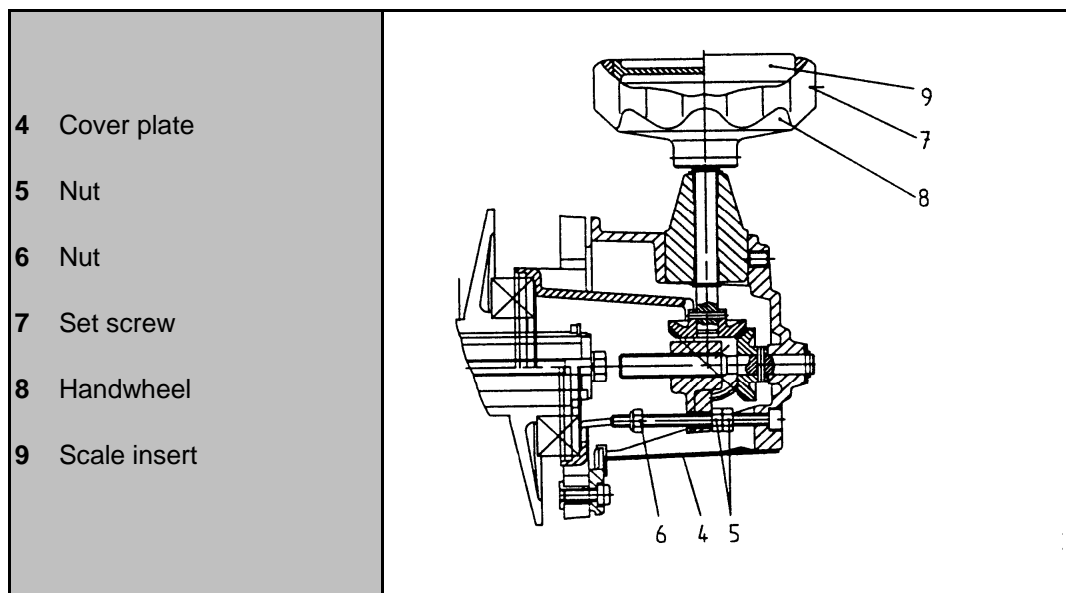

Fig. 11 Angled control WS



6.2.3 Changing the variable speed pulleys

Assembly of the control- and spring pulley (Fig.12)



- The variable speed pulleys must be fitted to the drive and output shaft with a sliding fit (do not use force, e. g. by hammering). Never fit too tight since, otherwise , the main hub would expand in the bore and prevent the sliding of the moveable pulley halves.
If necessary slightly relubricate the shaft.



Stop!

The moveable pulley sheaves, (fig. 2 and 3) of both variable speed pulleys must always be diagonally opposed (see fig. 12).

Fig.12

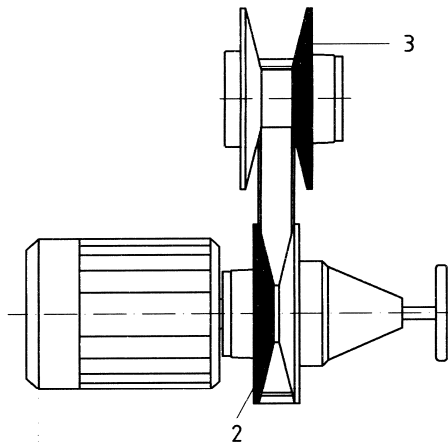

Axial locking of the control and spring pulleys (fig. 13)

- The pulleys must be fixed as shown in fig. 13.
- The fixing system can be also used as dismantling device (see fig.14)

Fig. 13

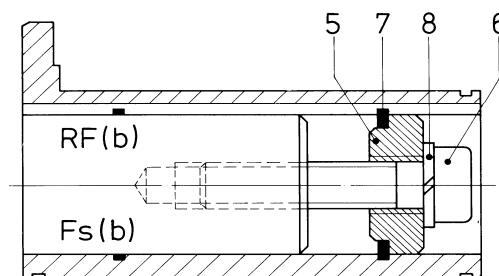

Dismantling of the control and spring pulleys (fig. 14)

- The variable-speed and spring pulleys can be removed by removing the cheese-head screw (Item 6), the spring washer (Item 8), the securing disc (Item 5) and the circlip (Item 7) from the bore. Place a smooth disc (Item 9) in front of the shaft stub in order to protect the shaft thread. Guide the attachment disc (Item 5) reversally into the bore and press the circlip (Item 7) back into the recess of the bore. The variable-speed and spring pulley can now be removed from the shaft by screwing in a hexagon-head screw Item 10). For the thread size of the fixing screw (pos. 5) see the following table.

Fig.14

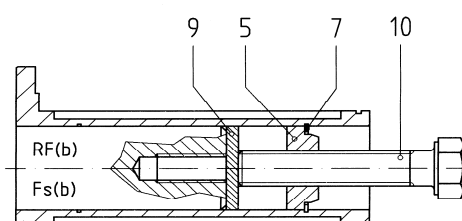

Shaft-Ø in mm	Thread of the shaft	Thread of Sec. Disc
>10 bis 13	M4	M6
>13 bis 16	M5	M6
>16 bis 21	M6	M8
>21 bis 24	M8	M10
>24 bis 30	M10	M12
>30 bis 38	M12	M16
>38 bis 50	M16	M20
>50 bis 85	M20	M24
>85 bis 130	M24	M30

Alignment (fig.15)



- The control and the spring pulley must be precisely aligned. This important precondition for the proper running of the drive is met when the stop shoulders of the drive and output are aligned. For this purpose it is absolutely necessary to re-use the distance washer at the motor shaft and the gearbox shaft (if any)!

Fig.15

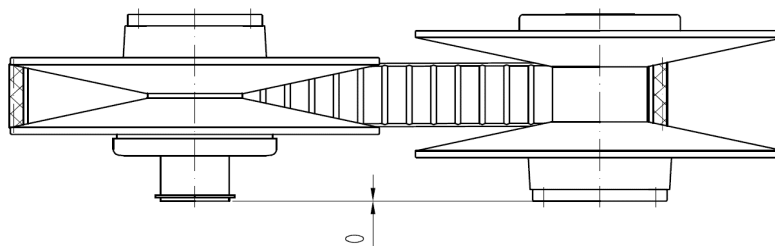

6.2.4 General Maintenance



The outside and inside of VG must be kept free from dust and dirt. When cleaning care must be taken that no means and procedures are being used that may produce static charges. Moreover care must be taken that neither dirt nor cleaning agents must not get inside the VG (f. e. by compressed air).

The penetration of abrasive dust must be completely avoided.

7 Troubleshooting

- If faults or malfunctions occur when operating the BERGES variable speed unit VG, please check the possible causes of the fault on the basis of the table below.
- If the fault cannot be remedied by any of the measures listed in the table or if the fault which has occurred is not attributable to one of the causes specified in the table please inform BERGES Antriebstechnik GmbH & Co. KG (for address see chapter 8, page 28)



Caution!

If faults necessitating a repair of the VG occur during the warranty period, such faults may be remedied only by BERGES Antriebstechnik GmbH & Co. KG. We advise you to enlist our customer service even if faults whose cause cannot be clearly determined occur after the warranty period has expired.

Faults	Possible cause	Remedy
The drive does not start	<ul style="list-style-type: none"> ▪ Main motor not connected or connected incorrectly 	<ul style="list-style-type: none"> ▪ Check motor connection
The drive slips	<ul style="list-style-type: none"> ▪ Wide V-belt is worn ▪ V-belt or running surface of the pulley is dirty. ▪ Too high load 	<ul style="list-style-type: none"> ▪ Change wide V-belt <p>Clean the dirty parts:</p> <ul style="list-style-type: none"> ▪ Clean V-belt with a dry cloth or paper. ▪ Clean the variable speed pulley with thinner or similar chemicals <ul style="list-style-type: none"> ▪ Check the measure power and reduce to the permissible values (see annexe)
Drive warms up excessively	<ul style="list-style-type: none"> ▪ Too high load ▪ VG is extremely dirty 	<ul style="list-style-type: none"> ▪ Check the measured power and reduce to the permissible values (see annexe) ▪ Clean the VG
Too high running noise	<ul style="list-style-type: none"> ▪ V-belt is damaged. Damage may occur after brief blocking or at intermiltend loading of the drive 	<ul style="list-style-type: none"> ▪ Change the V-belt ▪ Eliminate the cause
Meshing/grinding running noise	<ul style="list-style-type: none"> ▪ Bearing damage 	<ul style="list-style-type: none"> ▪ Change the VS-pulley ▪ Change the GFL or GTF ▪ Change the reduction gear box
Whistling noise	<ul style="list-style-type: none"> ▪ Belt is running on the ground of the pulley since the speed limits have not been properly adjusted after changing the V-belt. 	<ul style="list-style-type: none"> ▪ Correctly adjust the speed limits
Servomotor of the electrical remote control is not running	<ul style="list-style-type: none"> ▪ Servo motor not or incorrectly connected 	<ul style="list-style-type: none"> ▪ Check the motor connection

8 Stocking spare parts, after-sales servicing addresses

8.1 Stocking spare parts

- We advise you to stock the control pulley, the spring pulley and the V-belt in order to maintain the VG constantly ready for operation.
- Only use original BERGES parts.



Any liability or warranty on the part of Berges Antriebstechnik GmbH & Co. KG for damages resulting from the use of non-original replacement parts is excluded.

- Please always state the following when submitting orders for spare parts.

KB - Nr.	(see rating plate)
Type designation	(see rating plate)

8.2 Sales and Service addresses

- BERGES Antriebstechnik GmbH & Co.KG
Industriestraße 13
D-51709 Marienheide
Tel. (0 2264) 17 - 0
Fax. (0 2264) 17123
email: vertrieb@berges.de

9 Konformitätserklärung



EU-Konformitätserklärung *EU-Declaration of Conformity*

Berges Antriebstechnik GmbH & Co. KG erklärt, dass Verstellgetriebe der Typen VG1 bis VG7 als montierte Einheit aus Motor, Untersetzungsgetriebe oder Abtriebsflansch mit durchgehender Welle, aus Verstellung, Gehäuse, Verstellscheiben und Breitkeilriemen (RGAE) mit der

Berges Antriebstechnik GmbH & Co. KG certifies herewith, that the variable speed gears, type VG1 - VG7, as readily assembled unit, consisting of motor, reduction gearbox or gearbox flange with through shaft, of housing, adjusting unit and pulleys with wide V-belt (RGAE) comply with

Explosionsschutzrichtlinie 2014/34/EU übereinstimmen.

EU Directive 2014/34/EU for explosion-proof

Zündschutzart für Gerätegruppe II der Kategorie 2 und 3:
Protection type for apparatus group II of the categories 2 and 3:
EX II 2 G h IIB T4 Gb EX II 3 G h IIB T4 Gc
EX II 2 D h IIIC 135°C Db EX II 3 D h IIIC 135°C Dc

Angewandte Normen : • EN 1127 - 1 • EN 80079 - 36 • EN 80079 - 37
Applied standards : • EN 1127 - 1 • EN 80079 - 36 • EN 80079 - 37

Die technische Dokumentation für Getriebe der Kategorie 2 ist hinterlegt bei der benannten Stelle TÜV PRODUKT SERVICE GmbH
Ridlerstraße 31, D-80339 München.

*The technical documentation for gears of the category 2 has been lodged at the named authority TÜV PRODUCT SERVICE GmbH
Ridlerstraße 31, D-80339 München.*

**BERGES - Antriebstechnik
GmbH & Co. KG**

Hersteller-Unterschrift :

Angaben zum Unterzeichner :

(Geschäftsleitung)

Datum :

27. Januar 2021

BERGES ... alles bestens geregelt



Power and torque curves

The power and torque curves presented in this paper specify the intended use of the variable speed units VG.

The continuous line in the diagrams represents power course over the whole speed range, the broken line represents the course of the torque.

This is based on a service factor of 1,1. When a higher service factor is required (approximate determination as per fig. 2) the power and torque values to be read have to be reduced by this value. If the calculated values are exceeded by the power consumption of the application the drive will be overloaded and is no longer used as intended. In those cases the load must be reduced to the permissible values.

The output speeds as shown in the horizontal X-axis can be reached at the specified operation speed of the motor and refer to the pure variable speed unit (RGAE, fig. 1). If the output shaft of the complete unit VG (see fig. 1) is a single bearing shaft with $I = 1$ in a gearbox flange (GFL – fig. 2) or gearbox foot (GTF – fig. 3) the output speed of the RGAEs corresponds to those of the shaft. If, however, a reduction gearbox (fig. 4) is fitted, the speeds of the shaft correspond to the speeds given in the graphs, but divided by the gear reduction ratio.

In general the output speeds at idle run are higher than during operation under load conditions. Motors with another operating speed than originally specified will change the output speeds in direct proportion.

In case of variable speed units VG with reduction gearbox the torques will be calculated by multiplying the corresponding values in the graphs with the reduction ratio of the gearbox. In case of VGs with GFL or GTF the values correspond directly to the values shown in the graphs.

In case of doubt contact the manufacturer. If not used as intended, i. e. if the variable speed drive is overloaded the warranty will be invalidated.

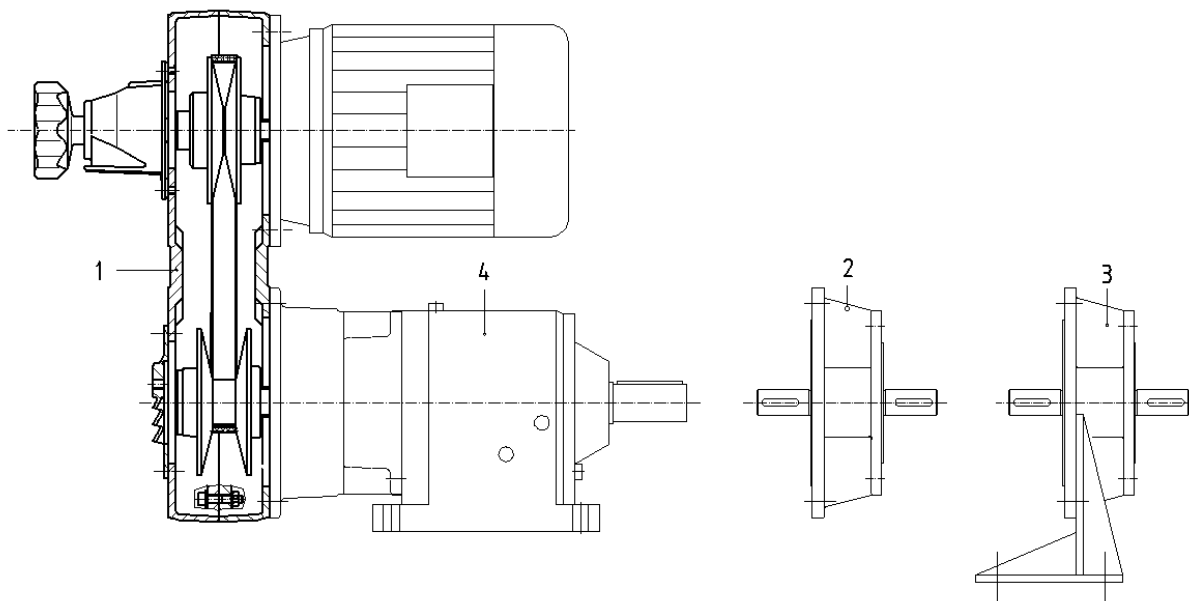

Fig 1

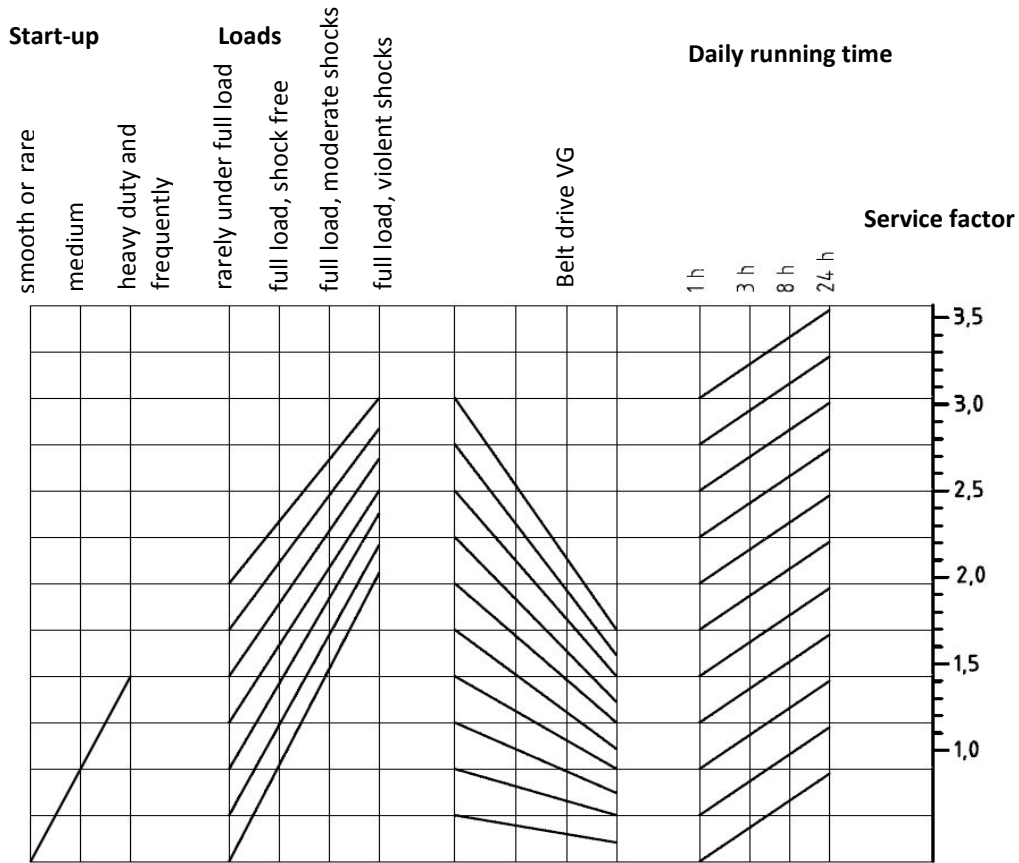

Fig 2: graphical determination acc.to Richter-Ohlendorf

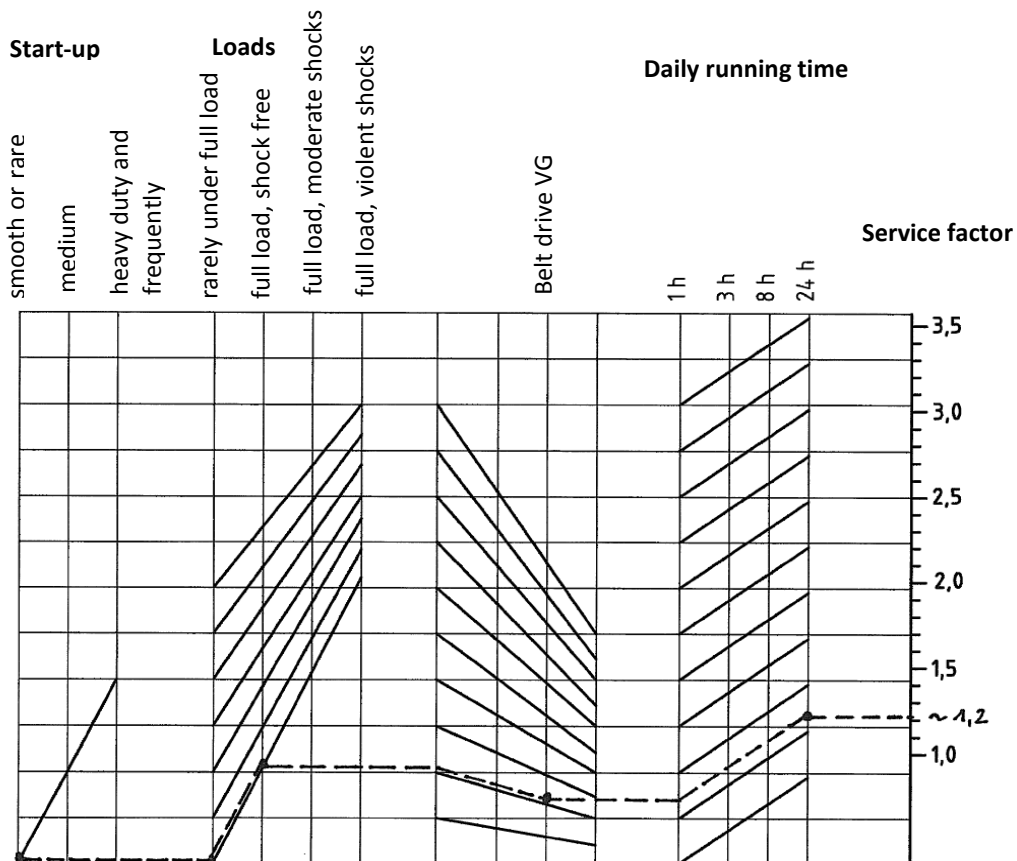
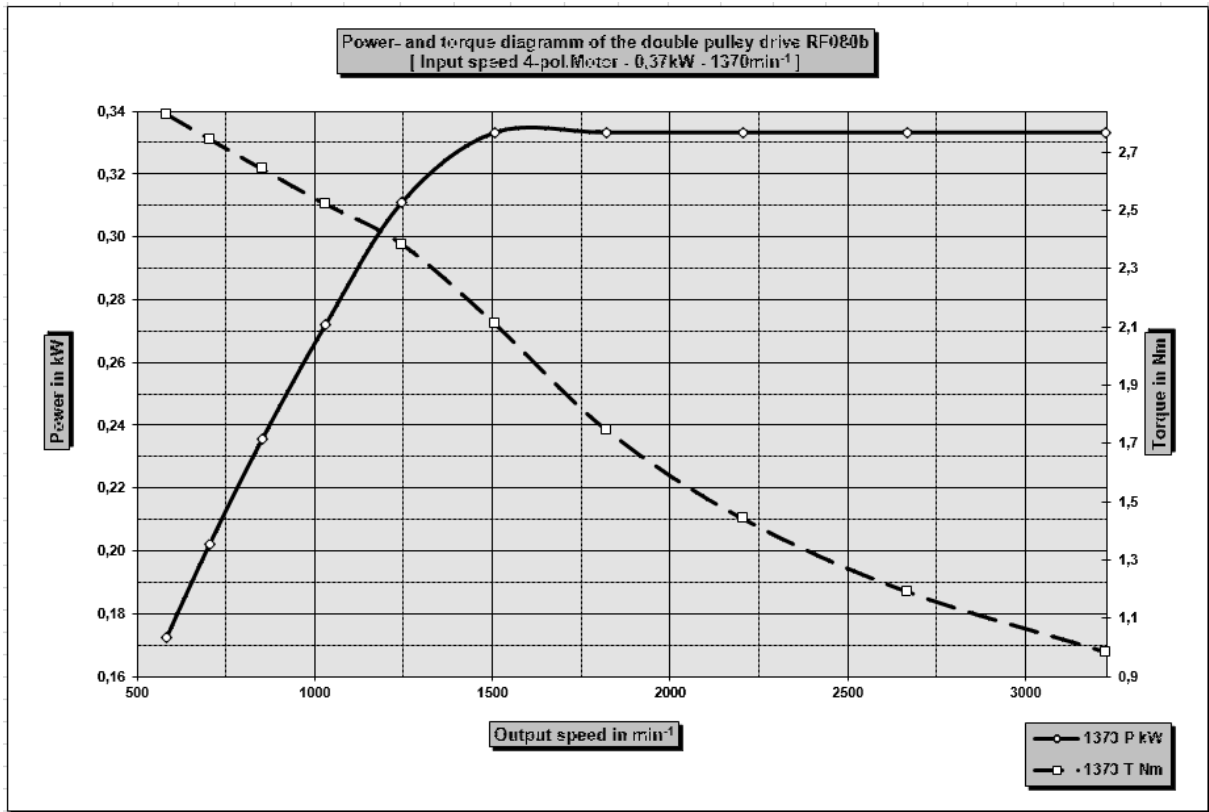

Fig. 3 – Example for „smooth or rare start-up“, „full load shock free“ and 24h daily running time

VG 1

RGAE1-080 $P_1 = 0,37 \text{ kW}$



RGAE1-080 $P_1 = 0,25 \text{ kW}$

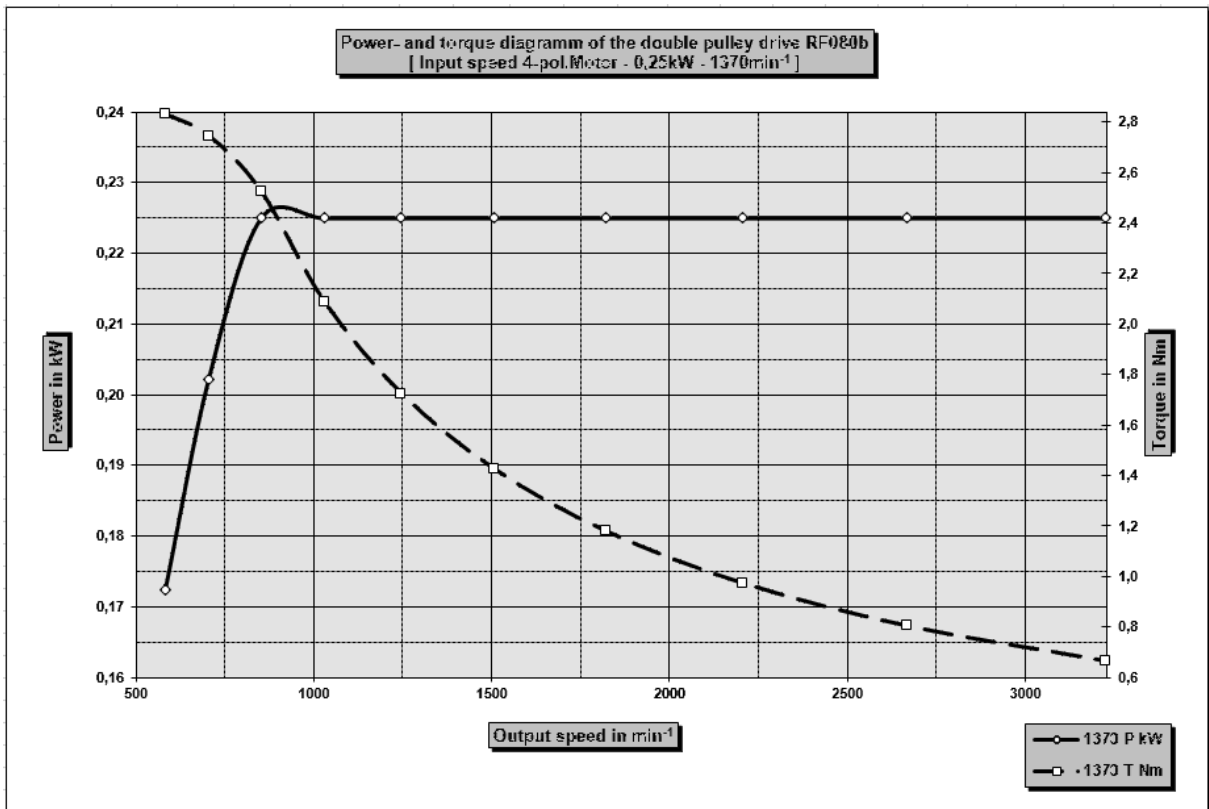

VG 2

RGAE2-100 $P_1 = 1,5 \text{ kW}$

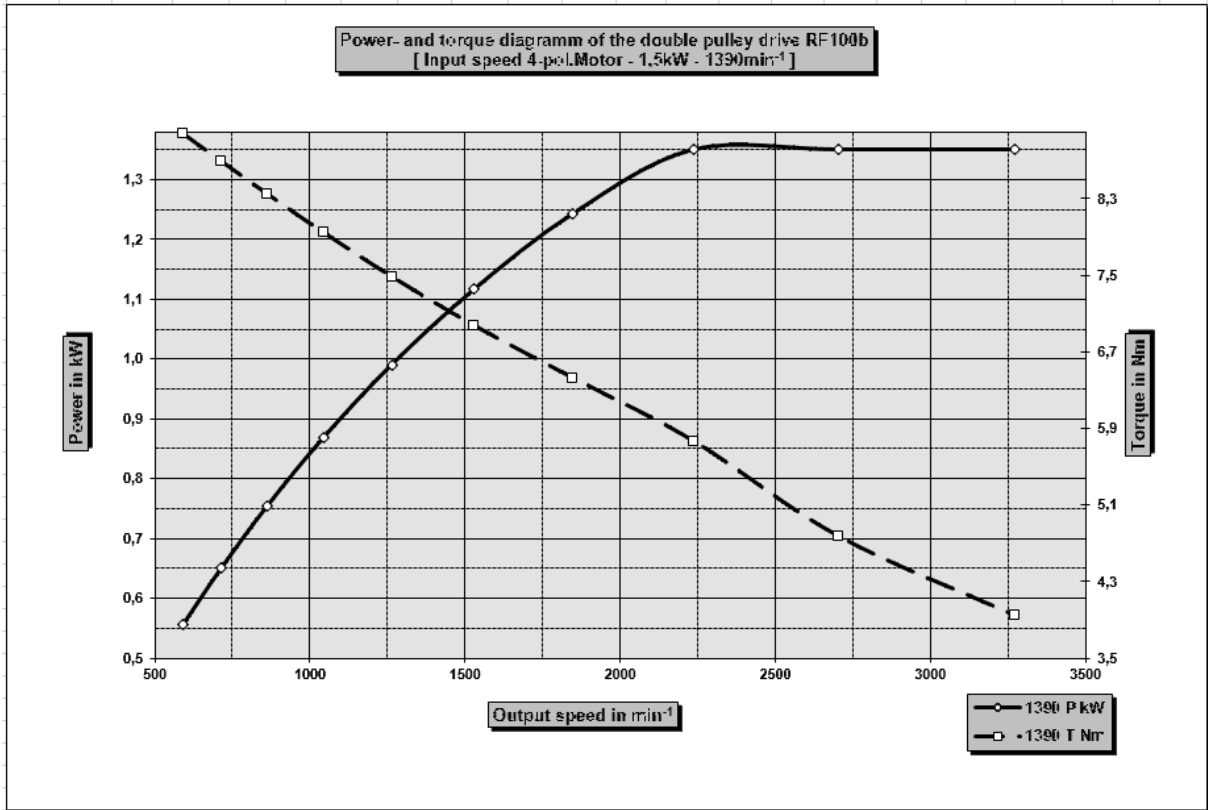

RGAE2-100 $P_1 = 1,1 \text{ kW}$

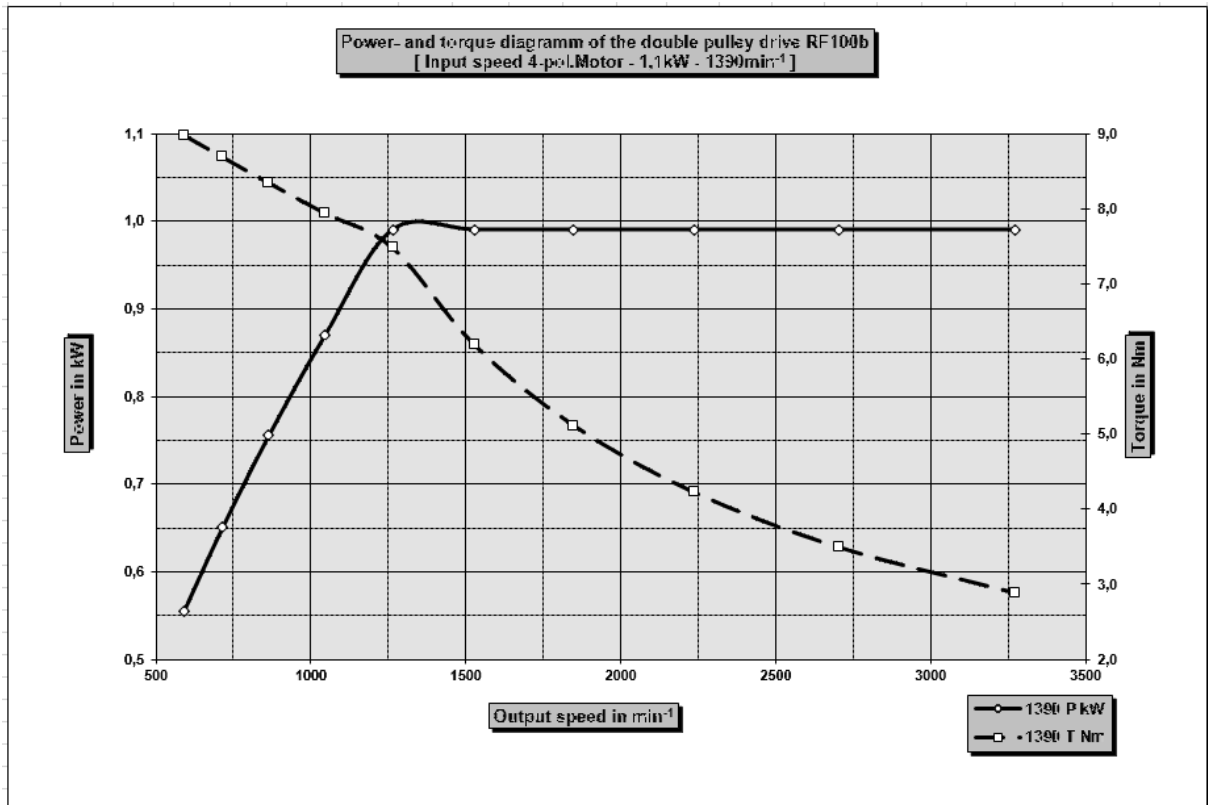

VG 2

RGAE2-130 $P_1 = 1,5 \text{ kW}$

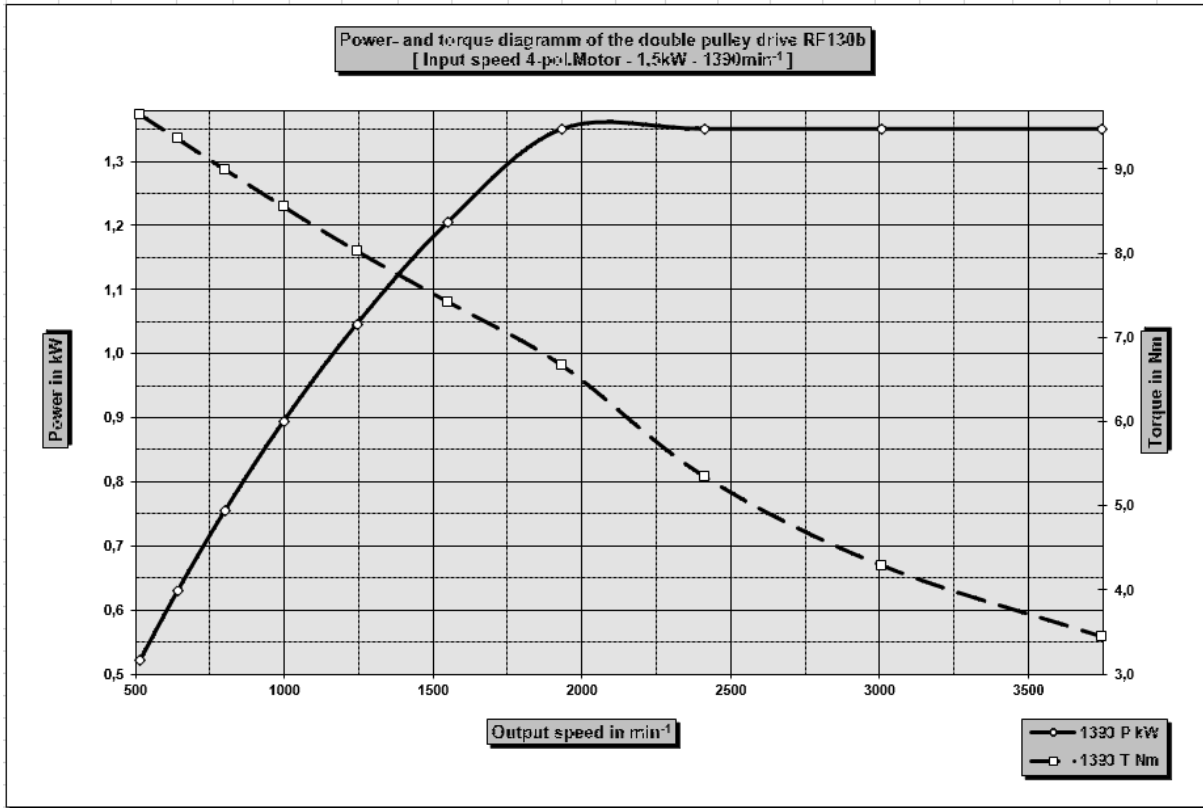

RGAE2-130 $P_1 = 1,1 \text{ kW}$

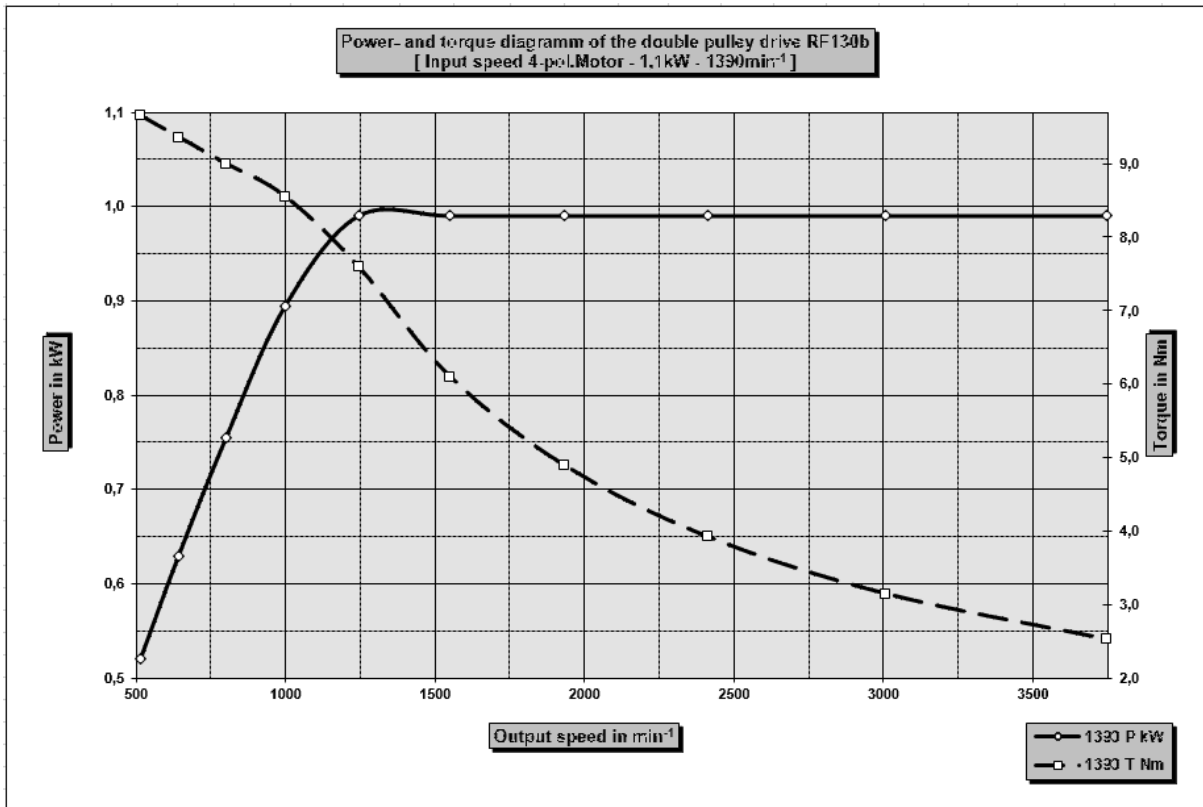

VG 3

RGAE3-150 $P_1 = 3,0 \text{ kW}$

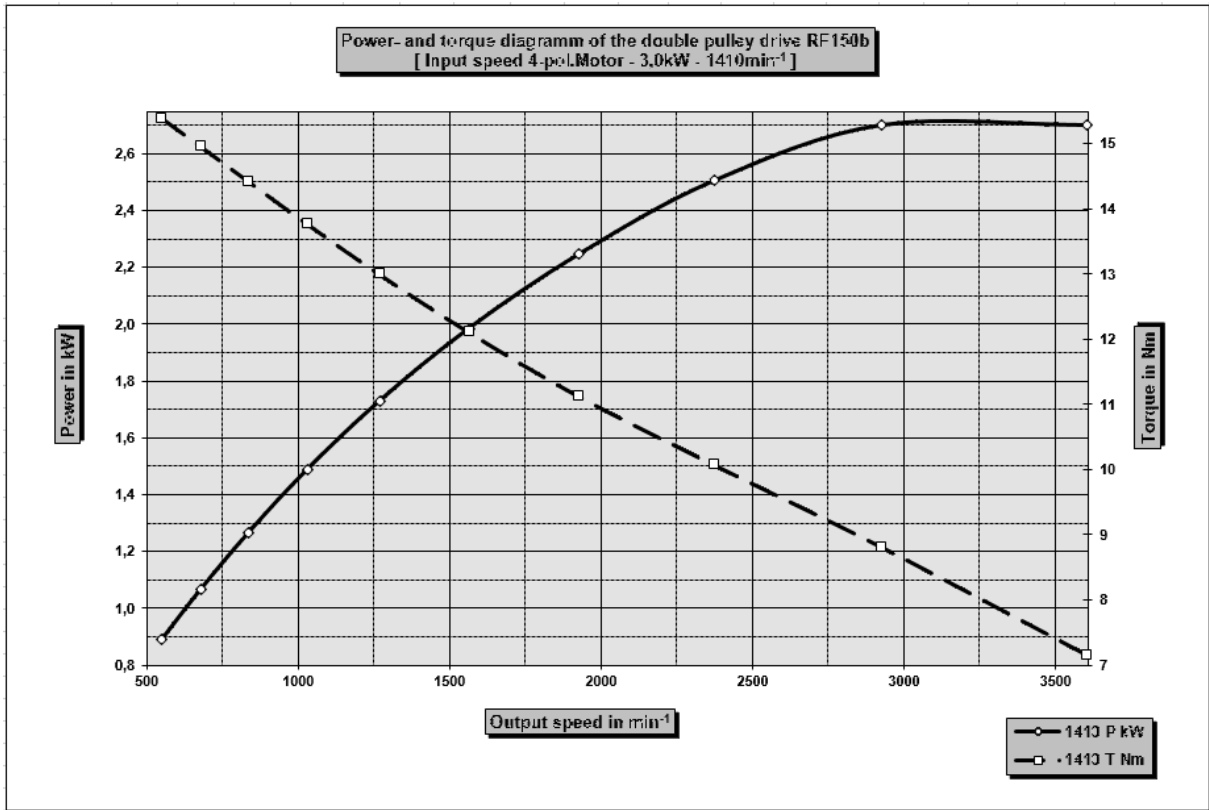

RGAE3-150 $P_1 = 2,2 \text{ kW}$

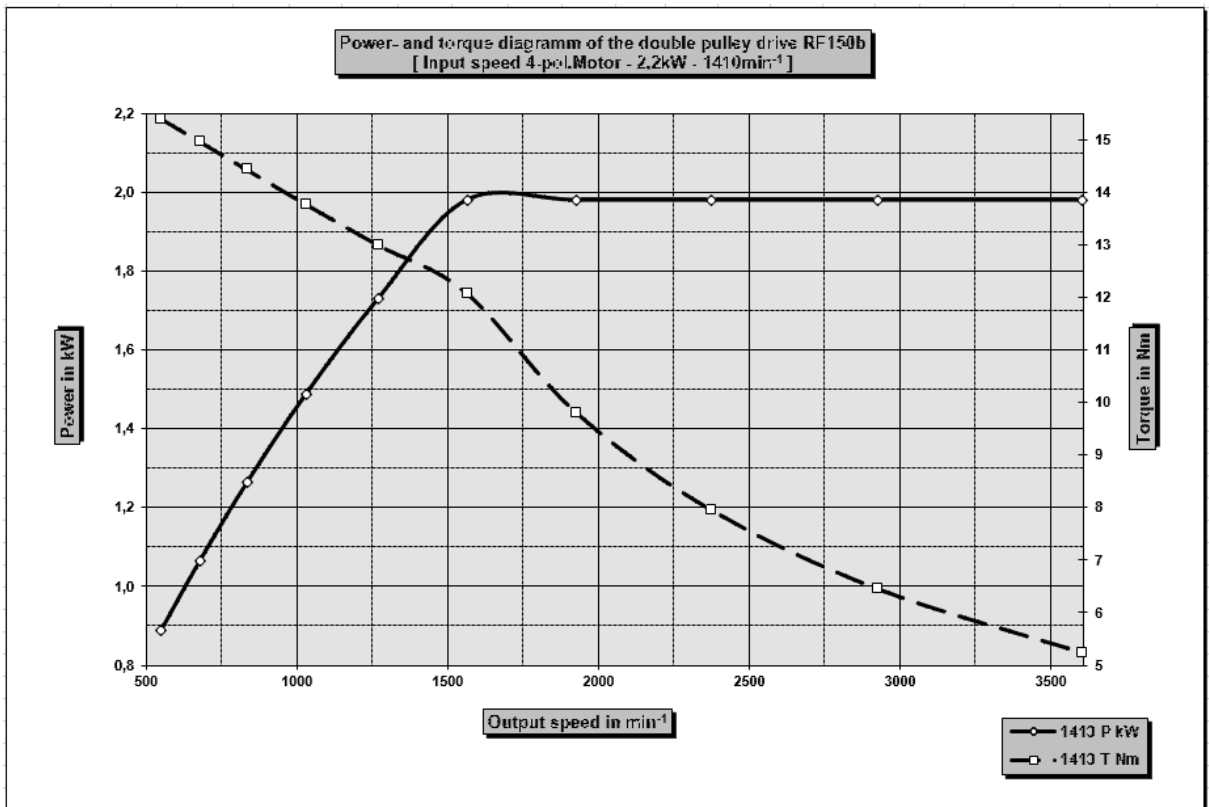

VG 3

RGAE3-190 $P_1 = 3,0 \text{ kW}$

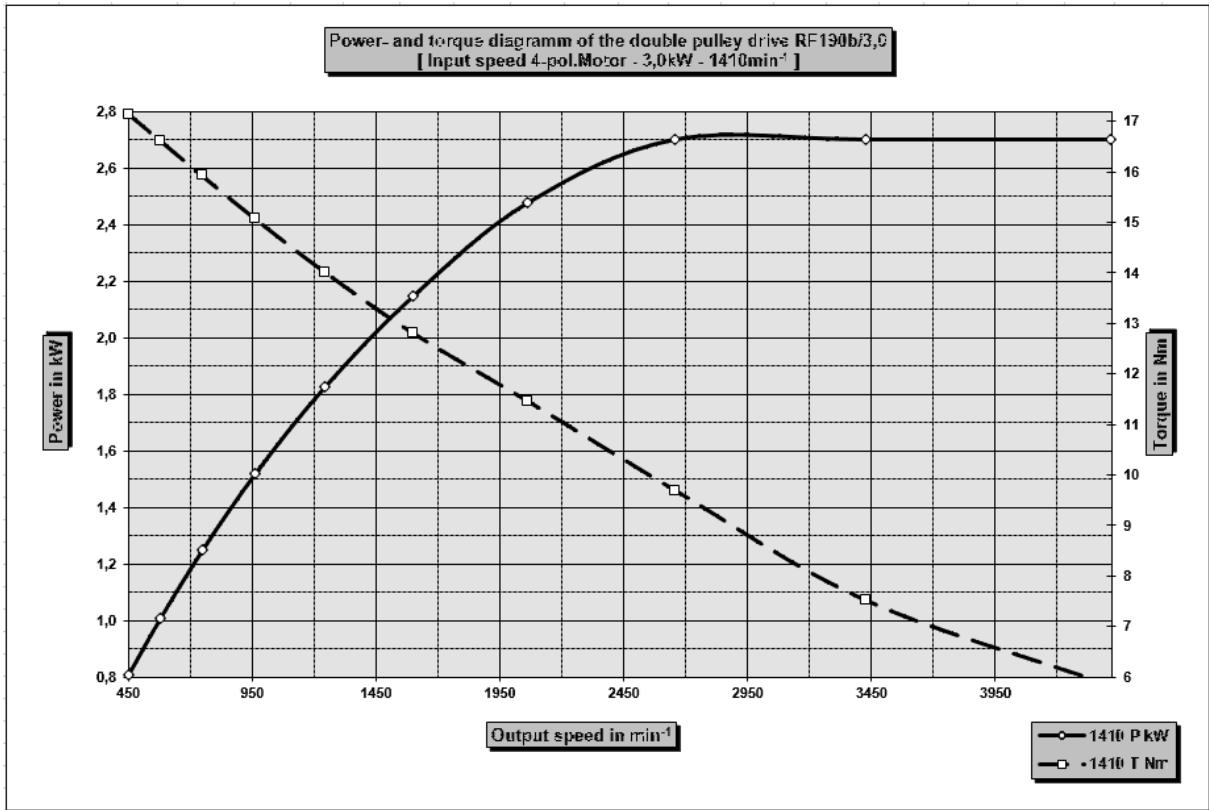

RGAE3-190 $P_1 = 1,5 \text{ kW}$

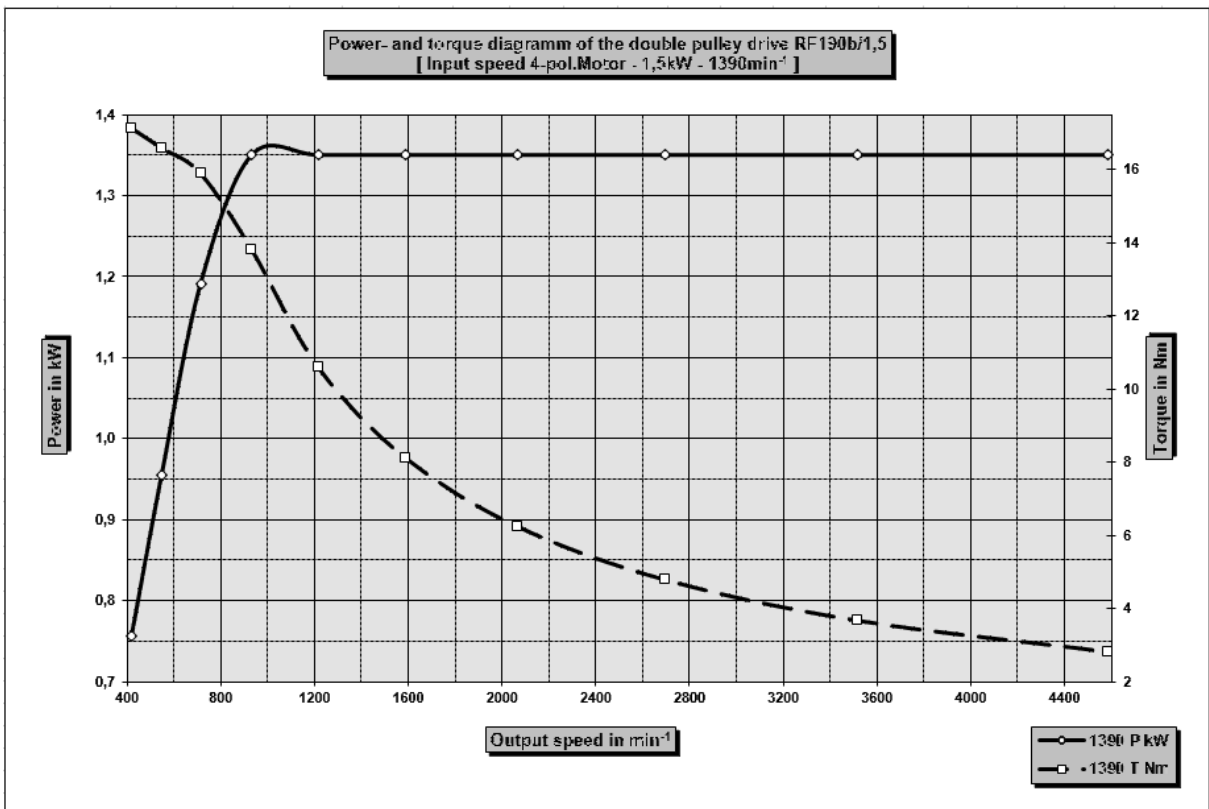

VG 3

RGAE3-196 $P_1 = 4,0 \text{ kW}$

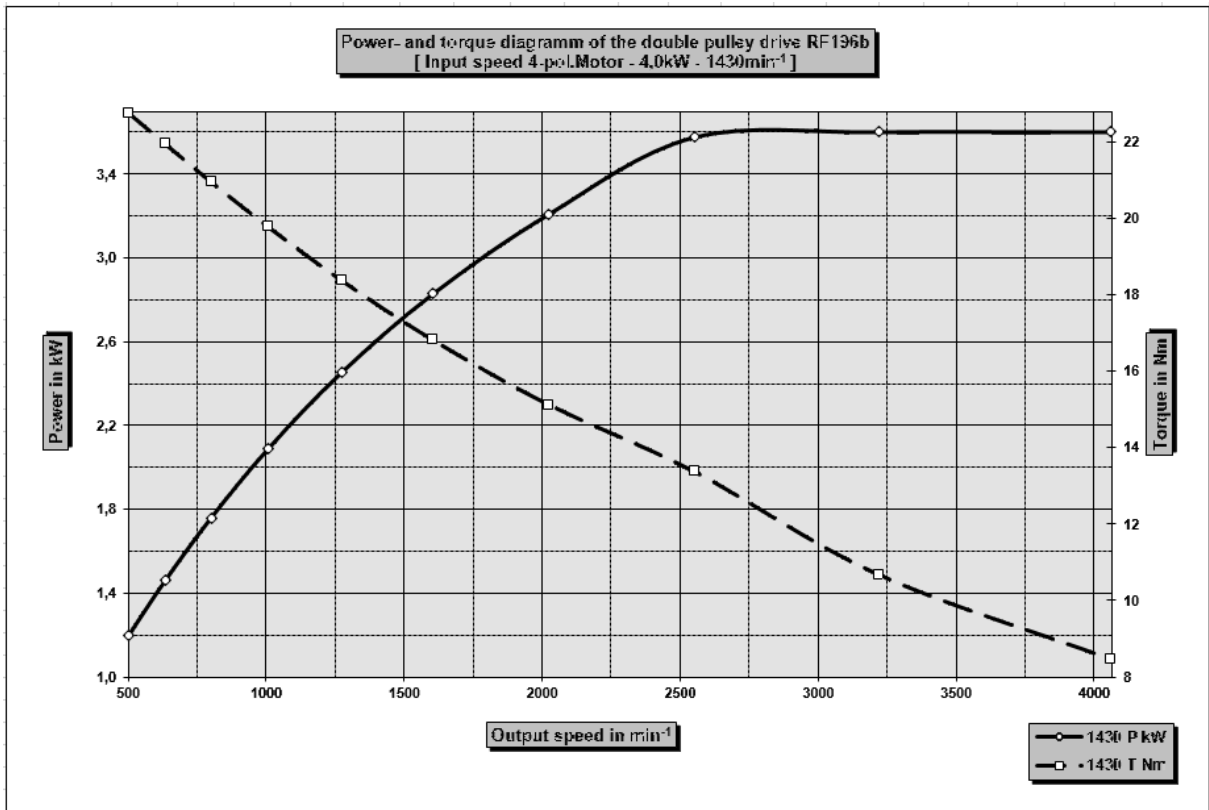

RGAE3-196 $P_1 = 3,0 \text{ kW}$

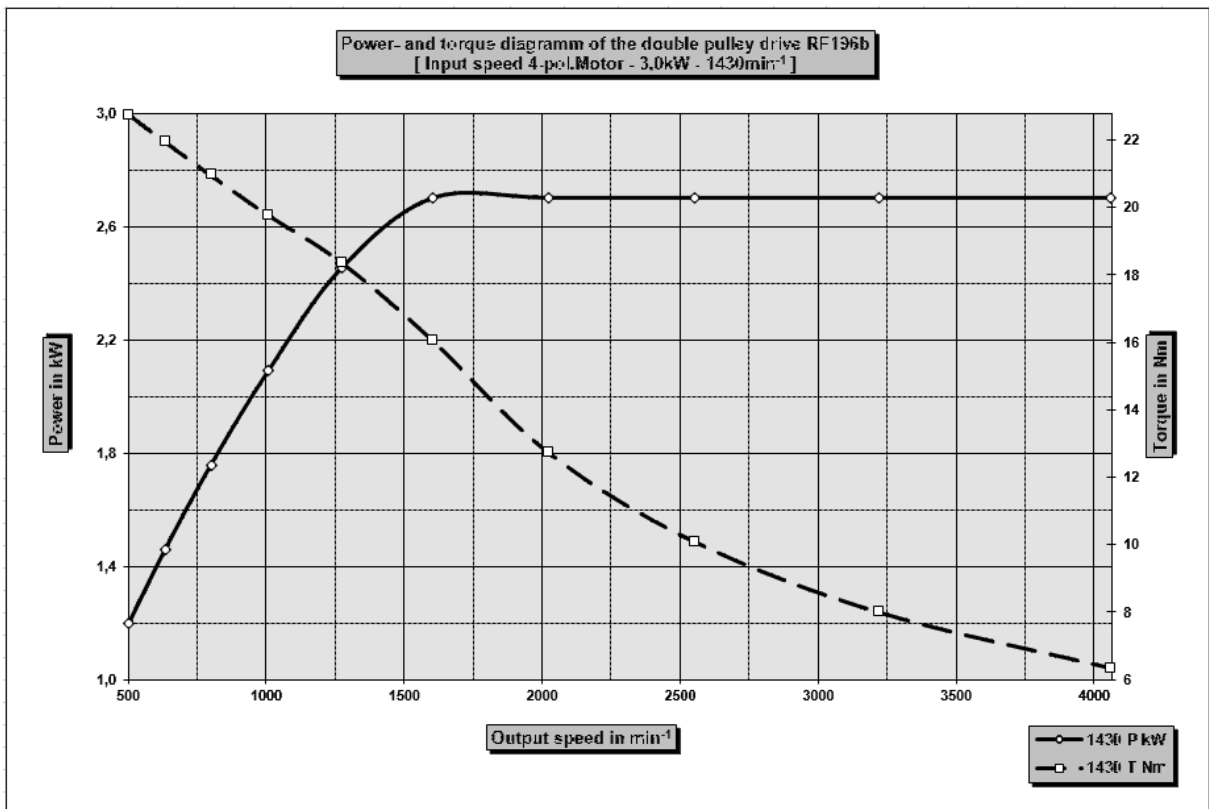

VG 4

RGAE4-210 $P_1 = 7,5 \text{ kW}$

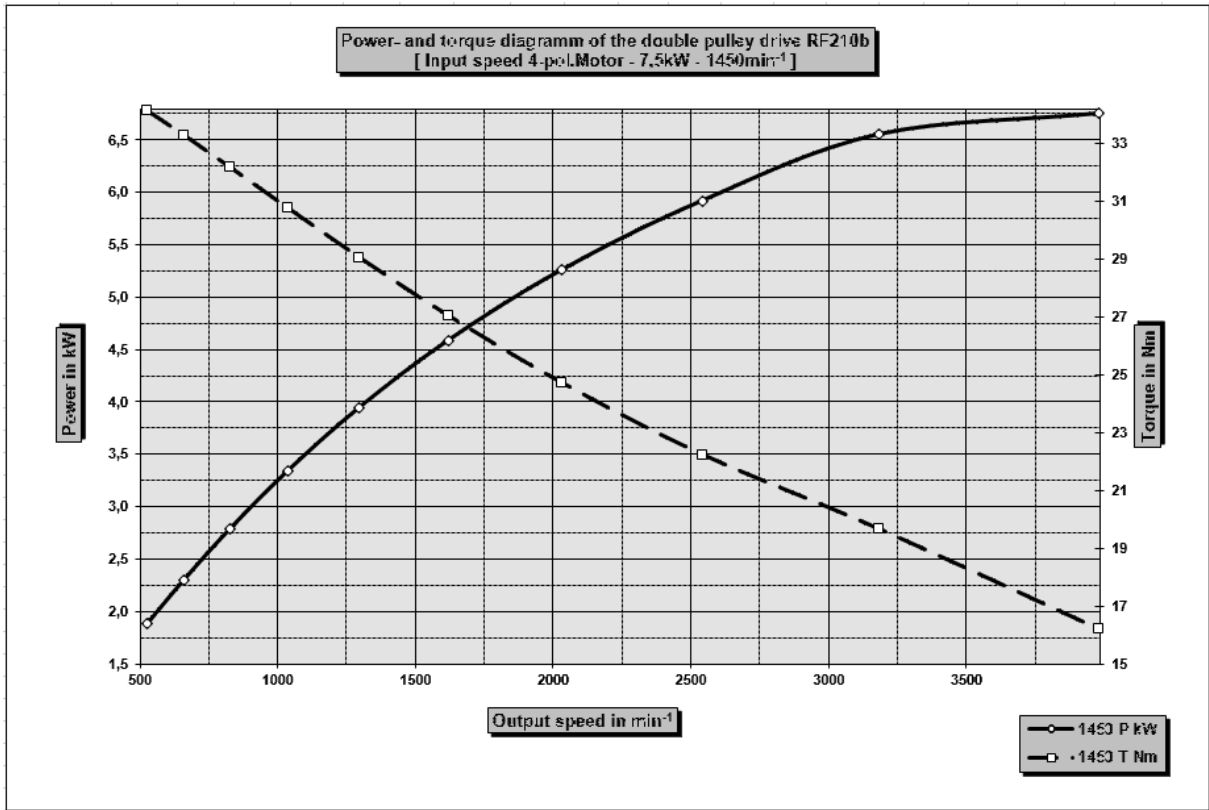

RGAE4-210 $P_1 = 5,5 \text{ kW}$

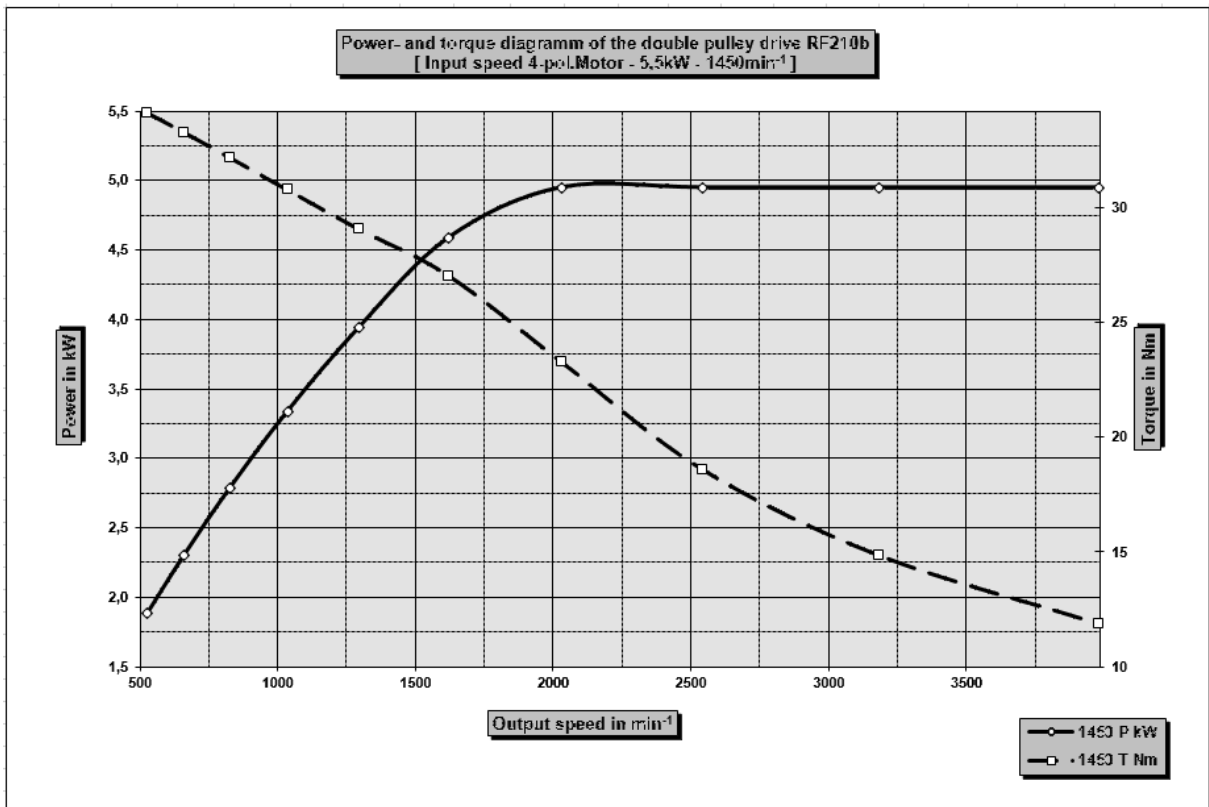

VG 4

RGAE4-235 $P_1 = 4,0 \text{ kW}$

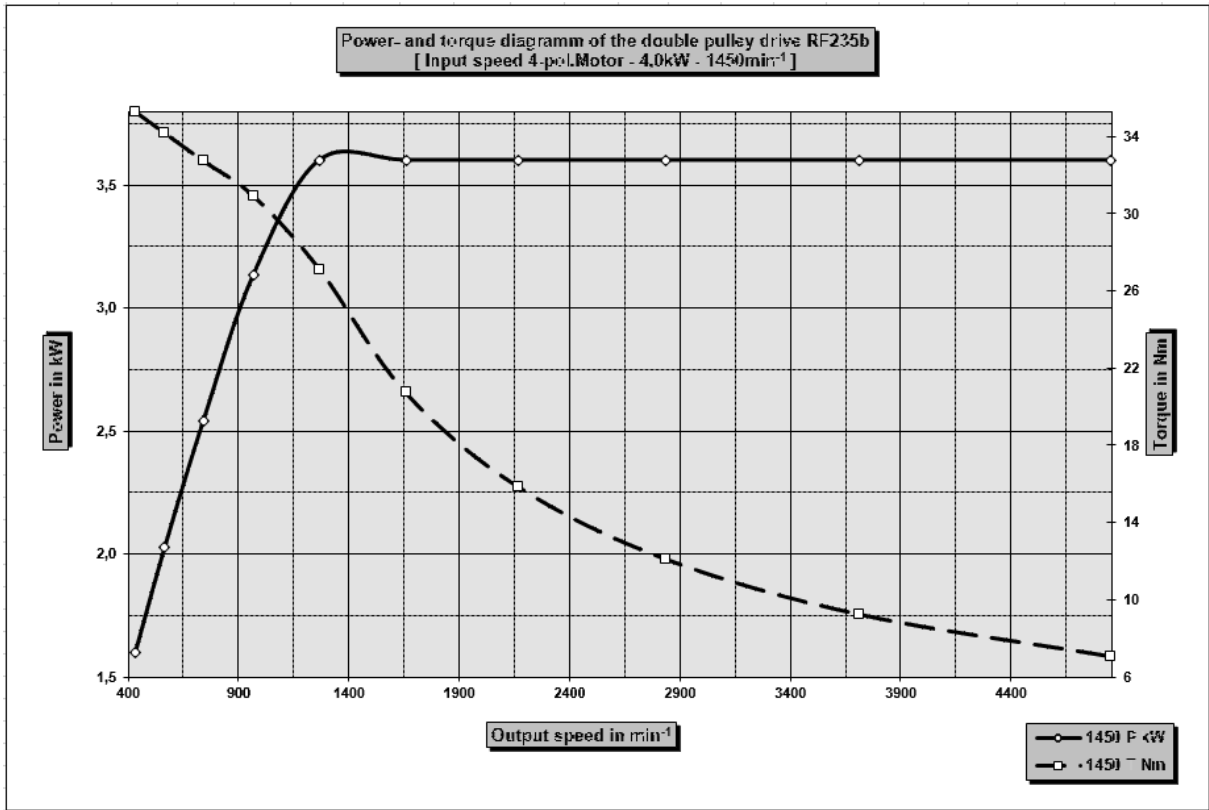

VG 5

RGAE5-250 $P_1 = 11 \text{ kW}$

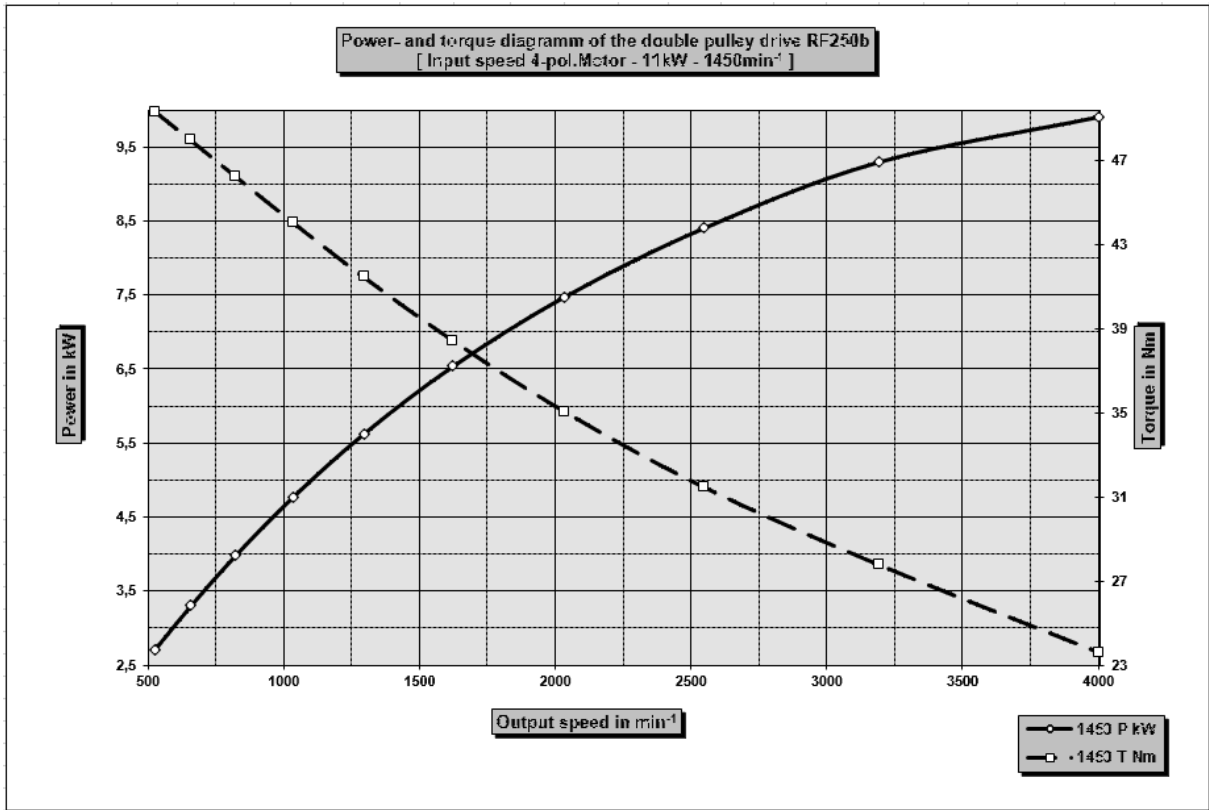

RGAE5-250 $P_1 = 7,5 \text{ kW}$

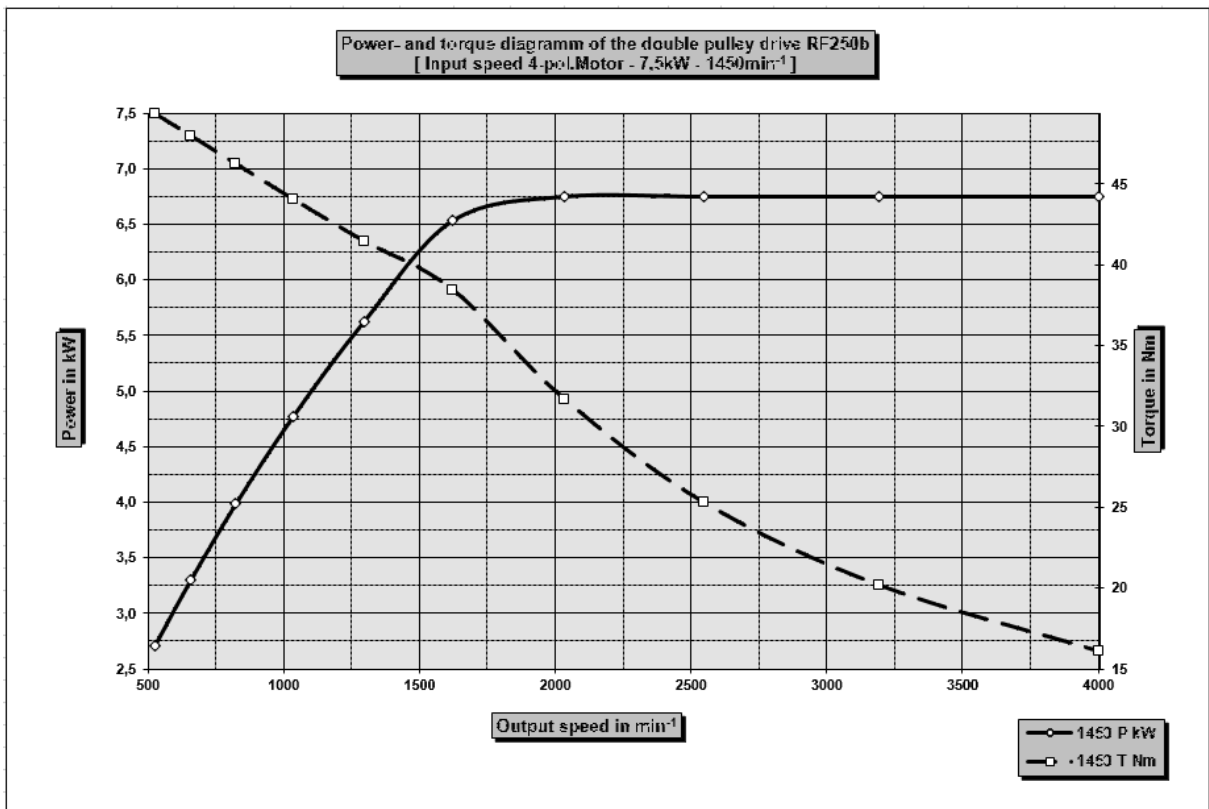

VG 5

RGAE5-280 $P_1 = 15 \text{ kW}$

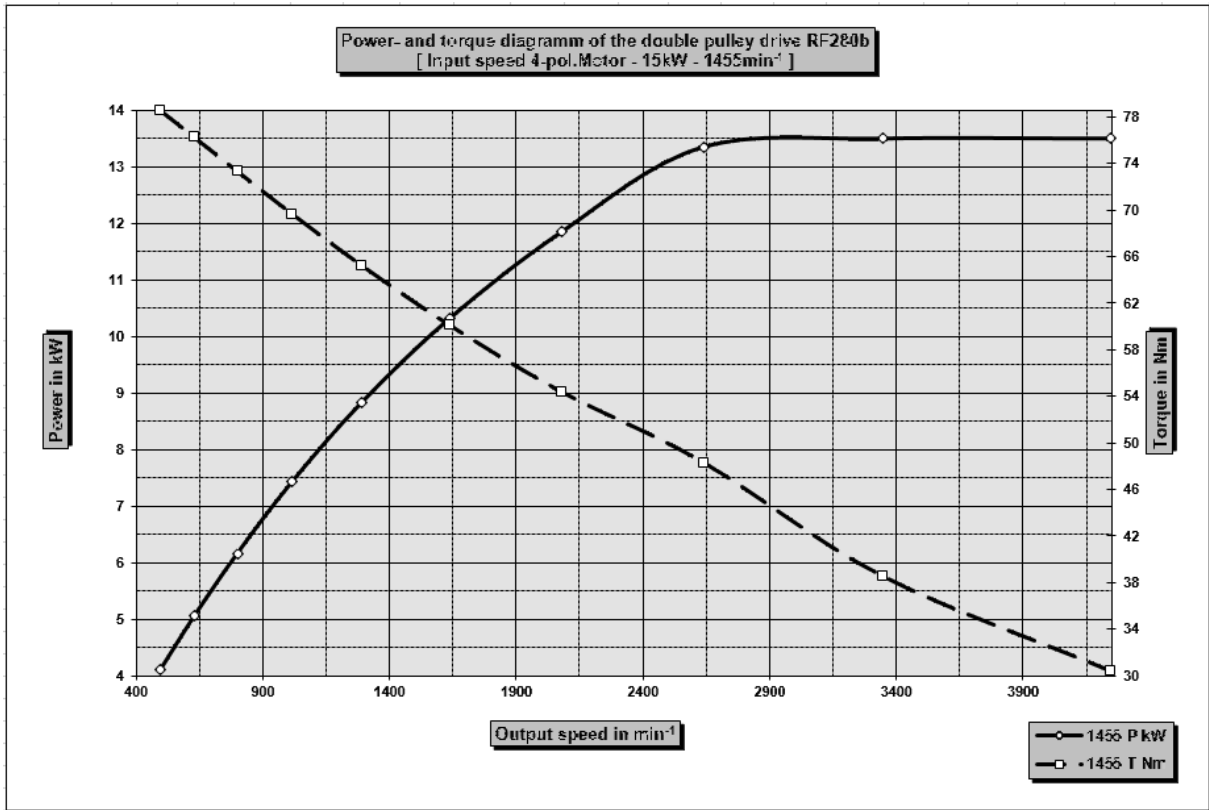

RGAE5-280 $P_1 = 11 \text{ kW}$

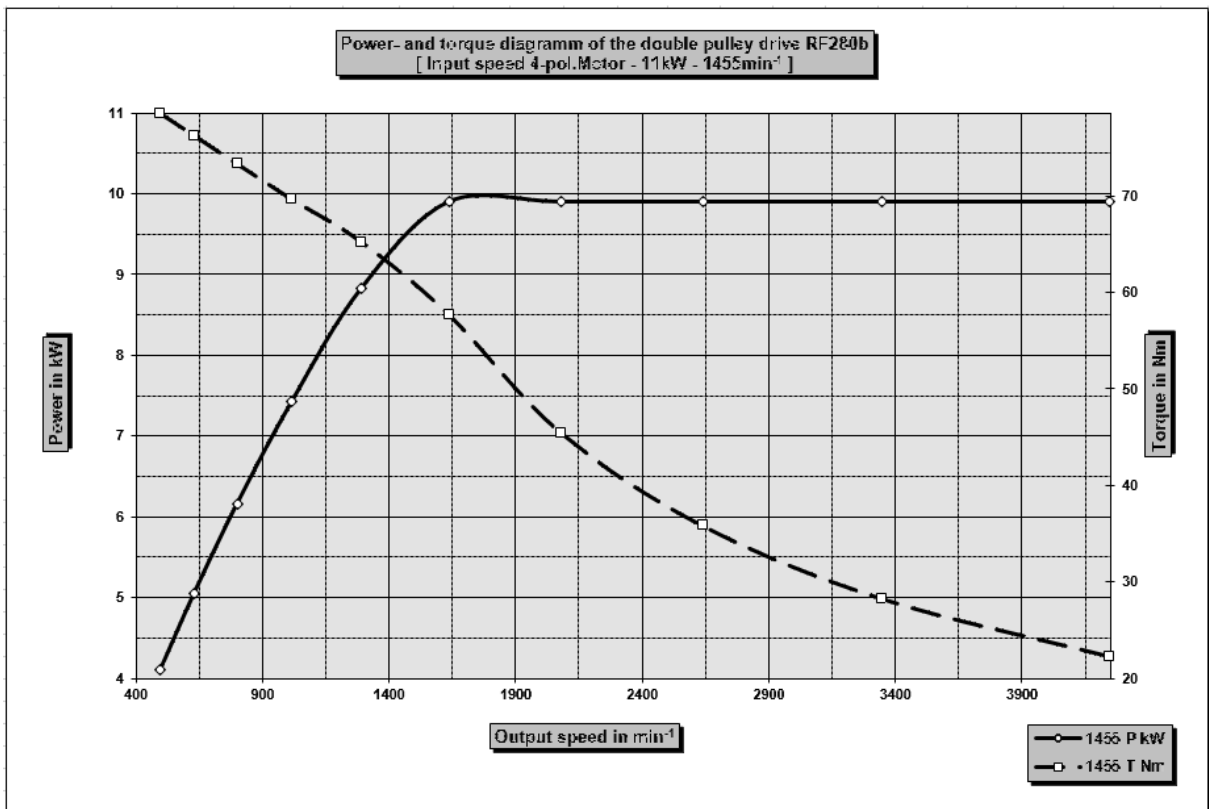

VG 6

RGAE6-300 $P_1 = 22 \text{ kW}$

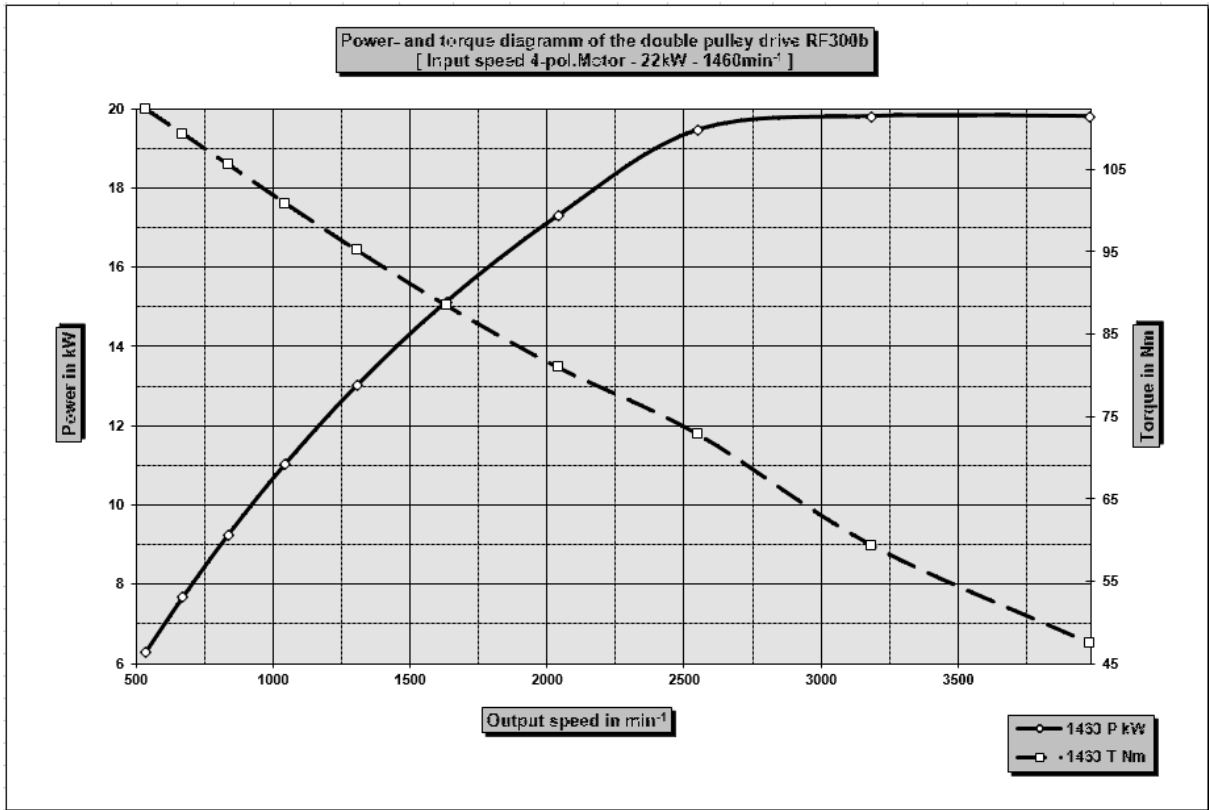

RGAE6-300 $P_1 = 18,5 \text{ kW}$

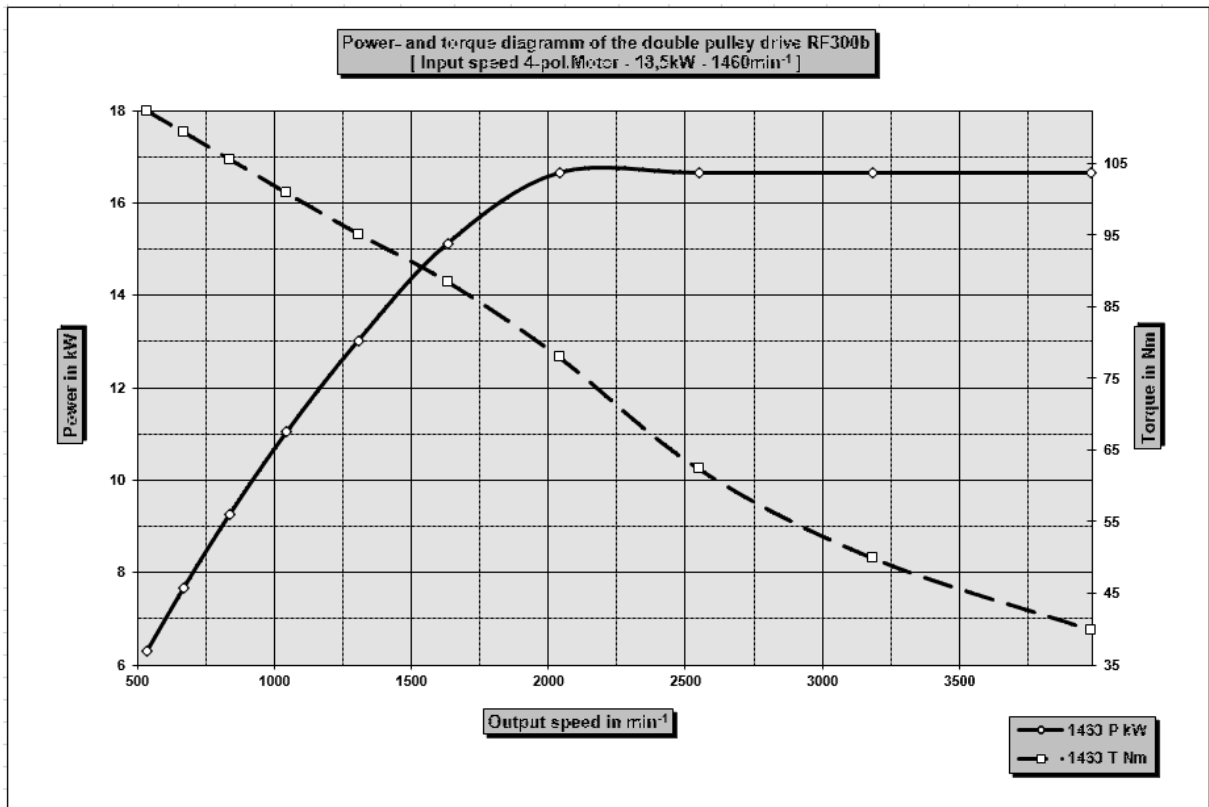

VG 6

RGAE6-350 $P_1 = 30 \text{ kW}$

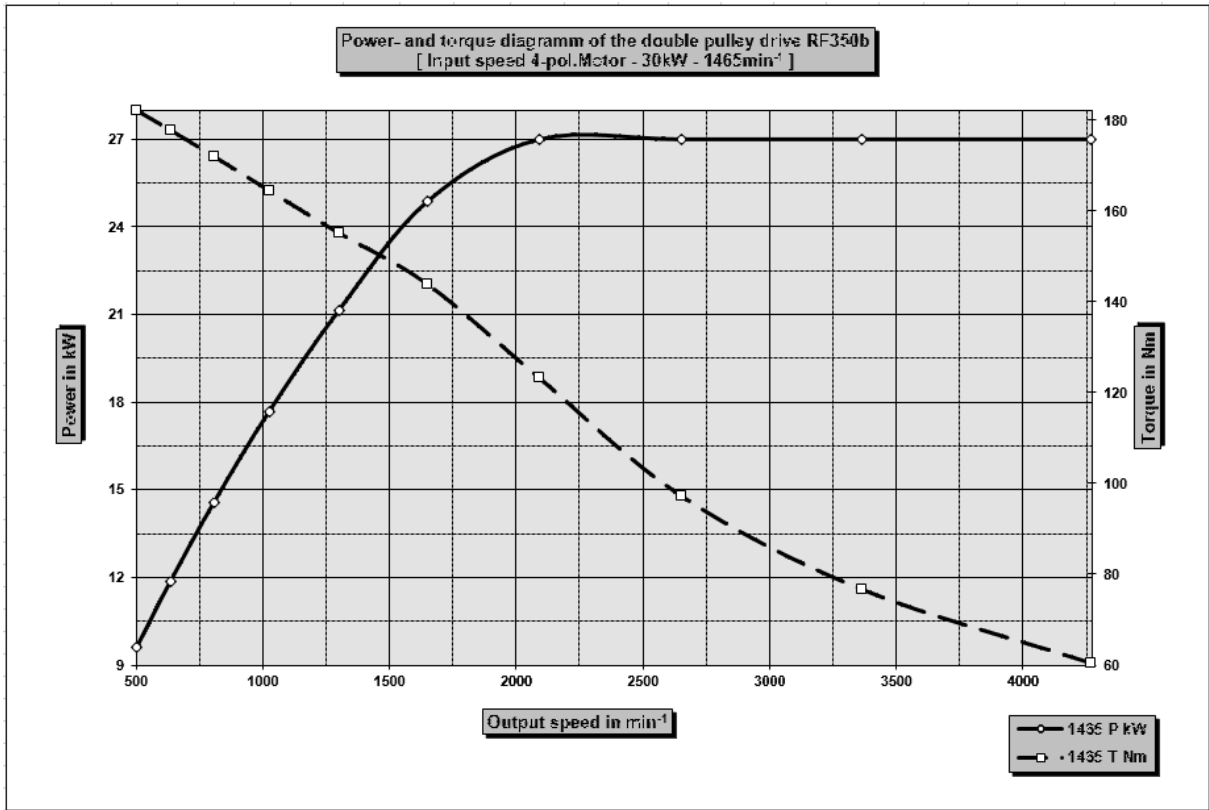

RGAE6-350 $P_1 = 22 \text{ kW}$

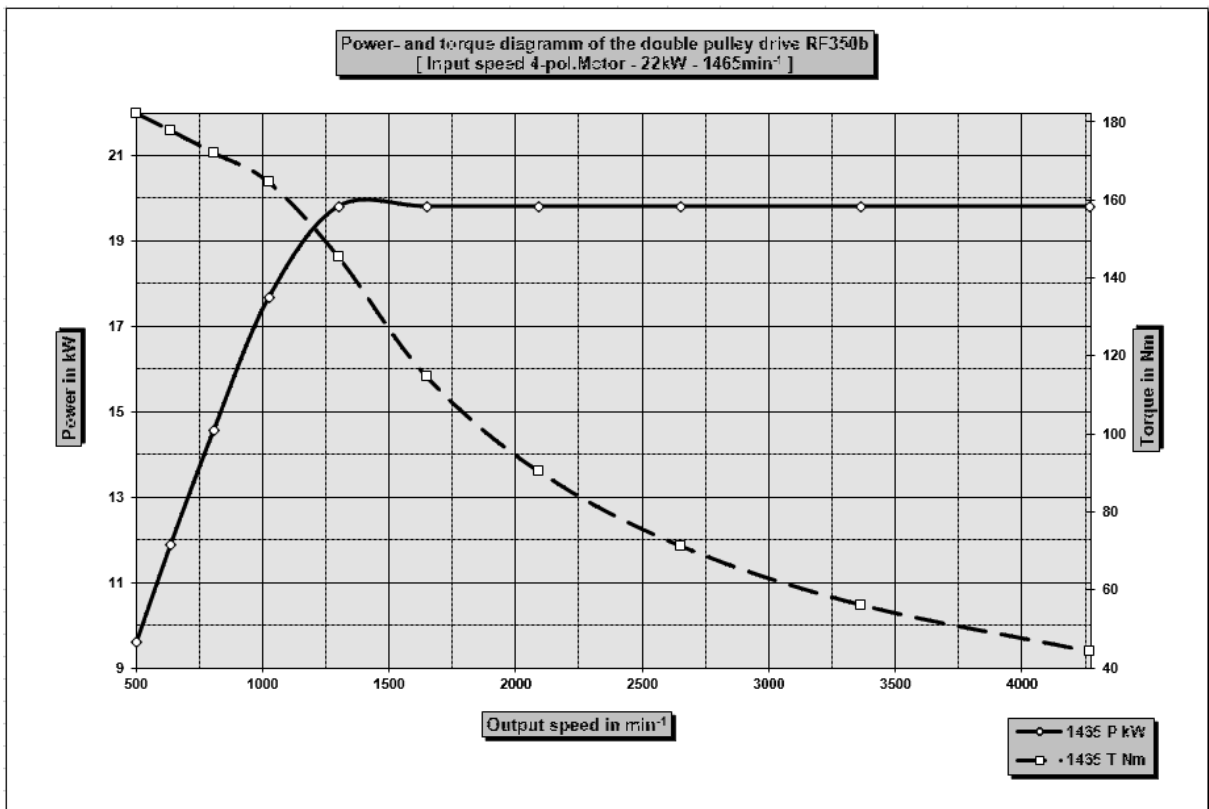

VG 7

RGAE7-375 $P_1 = 45 \text{ kW}$

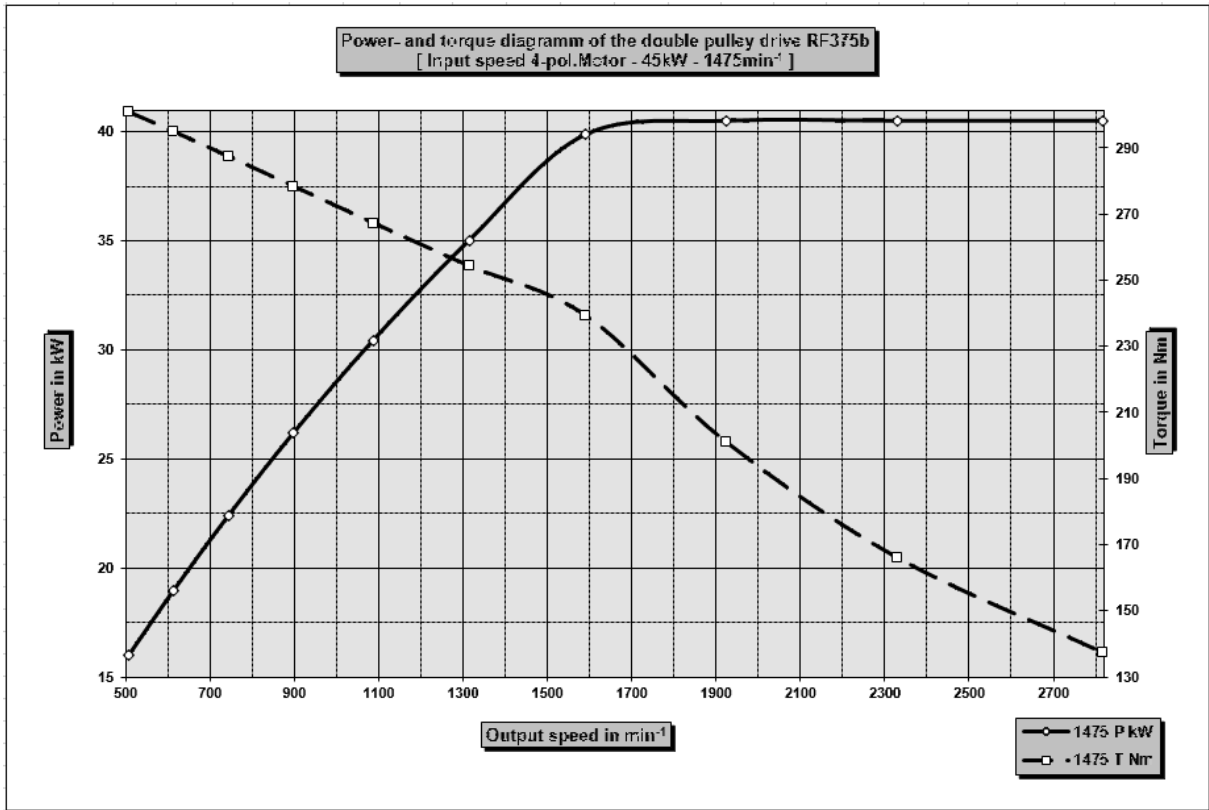

RGAE7-375 $P_1 = 37 \text{ kW}$

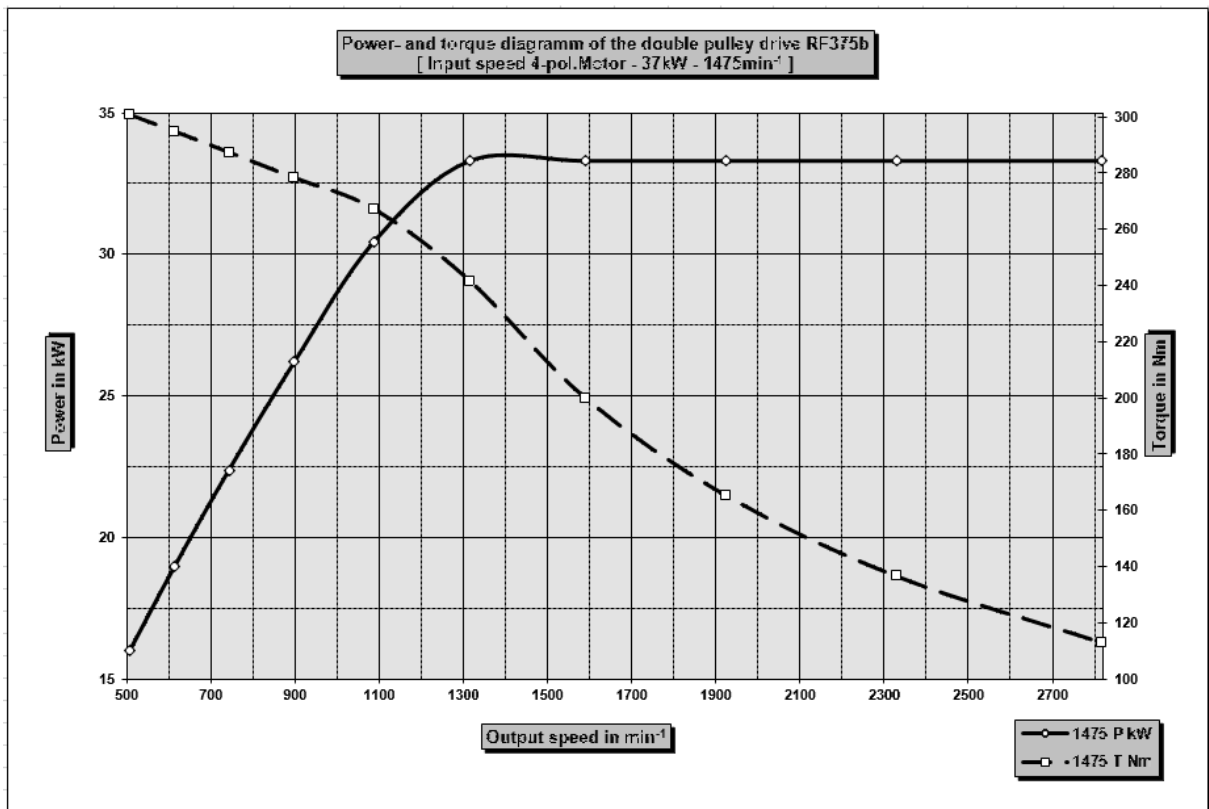

VG 7

RGAE7-400 $P_1 = 55 \text{ kW}$

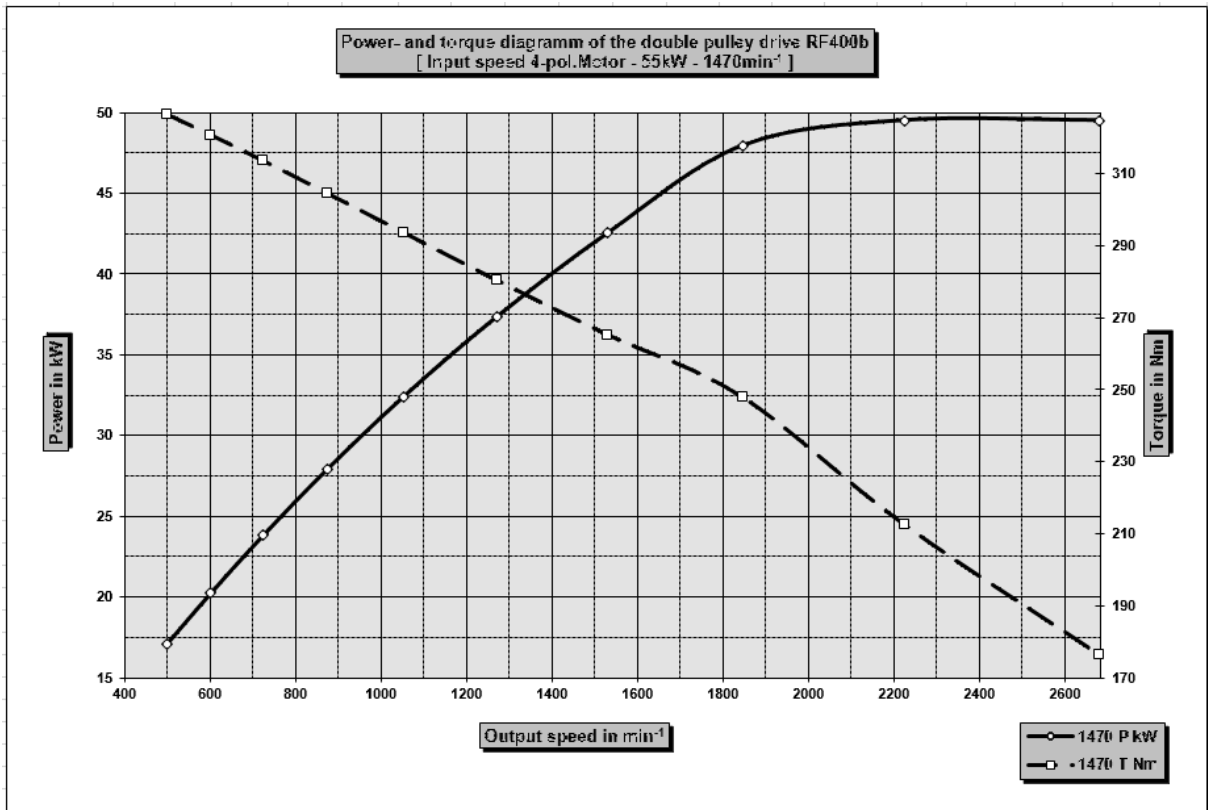

RGAE7-400 $P_1 = 45 \text{ kW}$

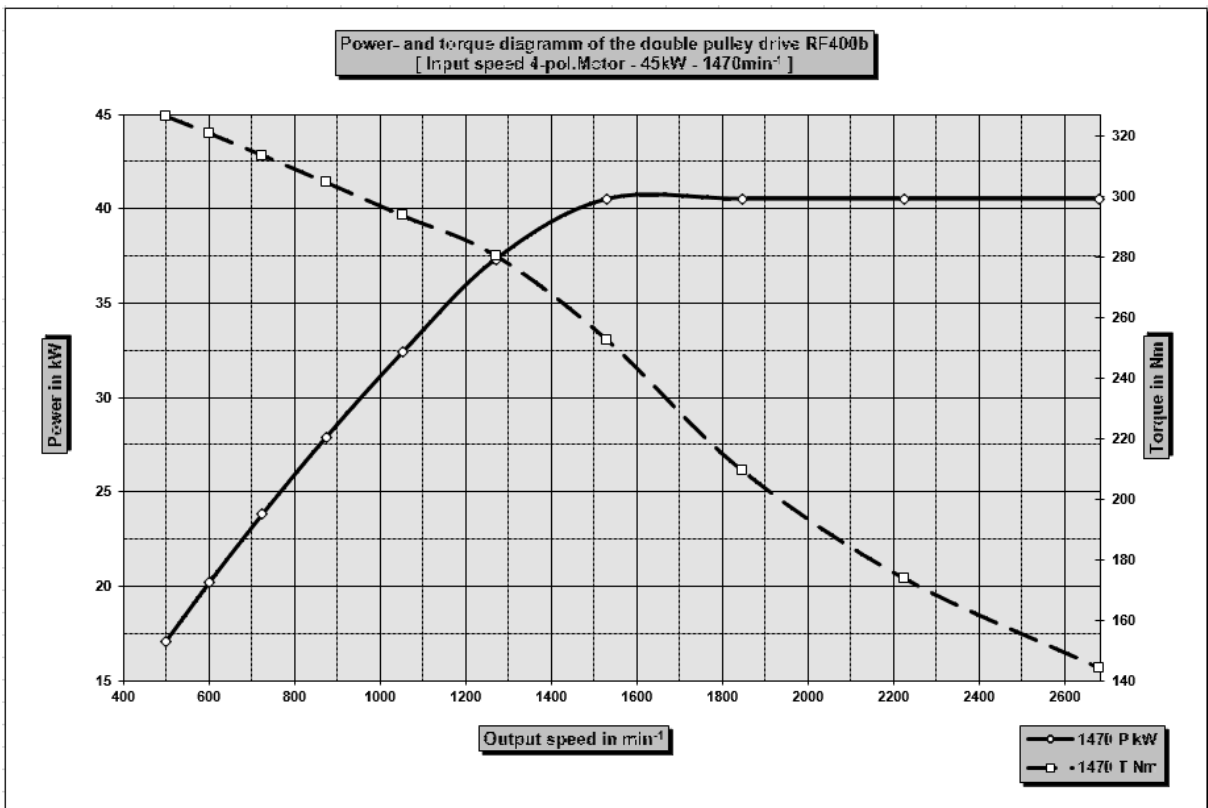

VG 8

RGAE8-450 $P_1 = 75 \text{ kW}$

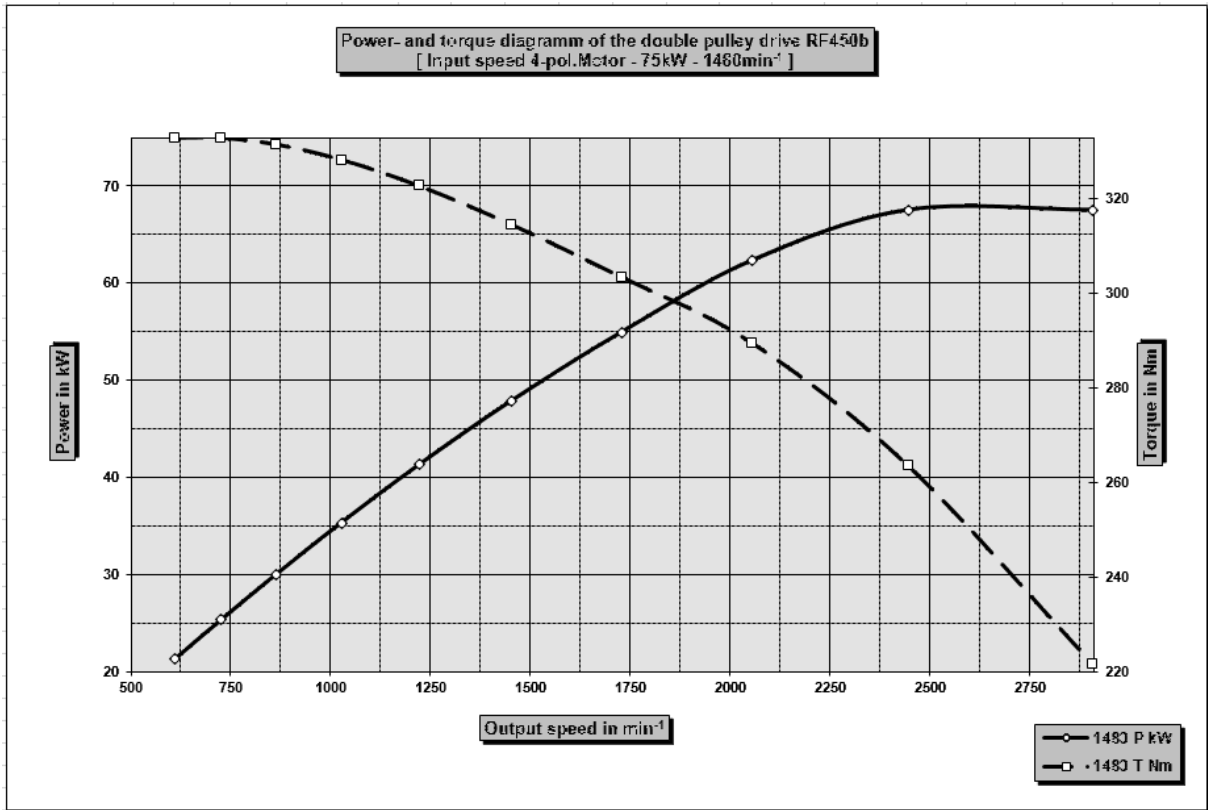

RGAE8-450 $P_1 = 55 \text{ kW}$

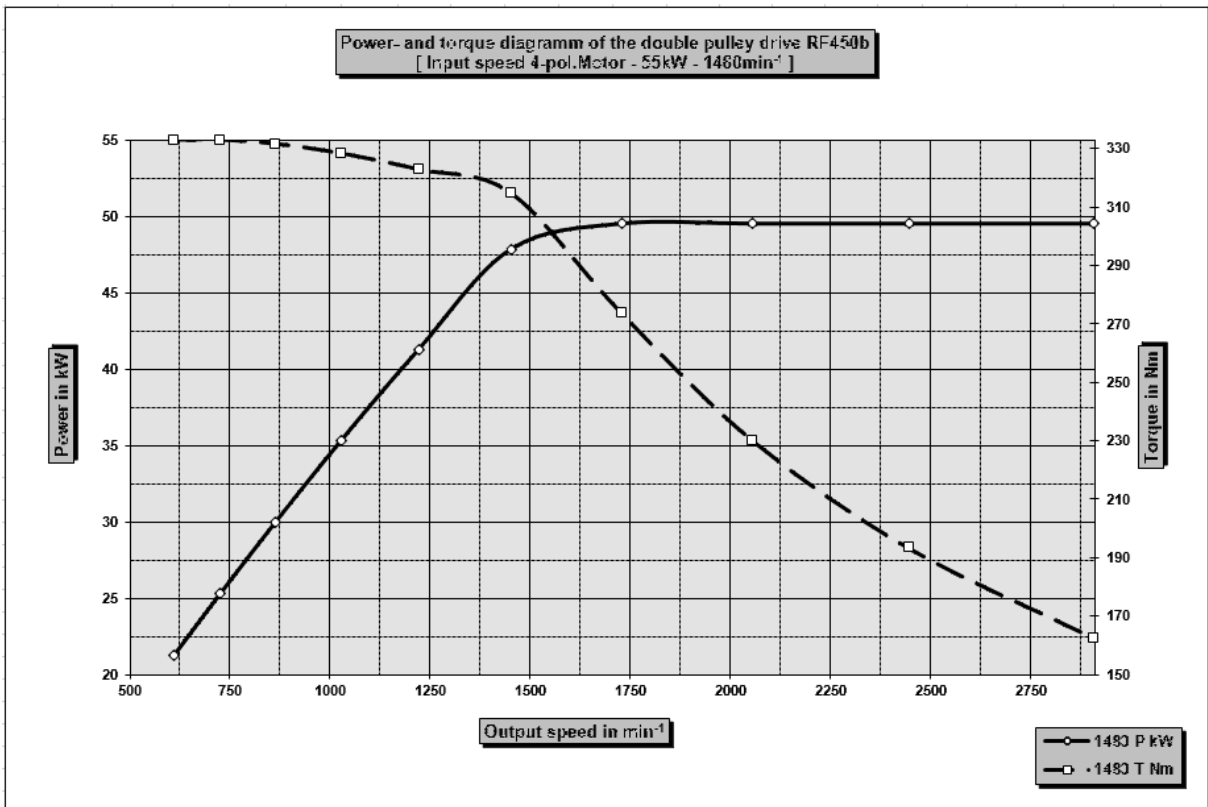

VG 8

RGAE8-500 $P_1 = 110 \text{ kW}$

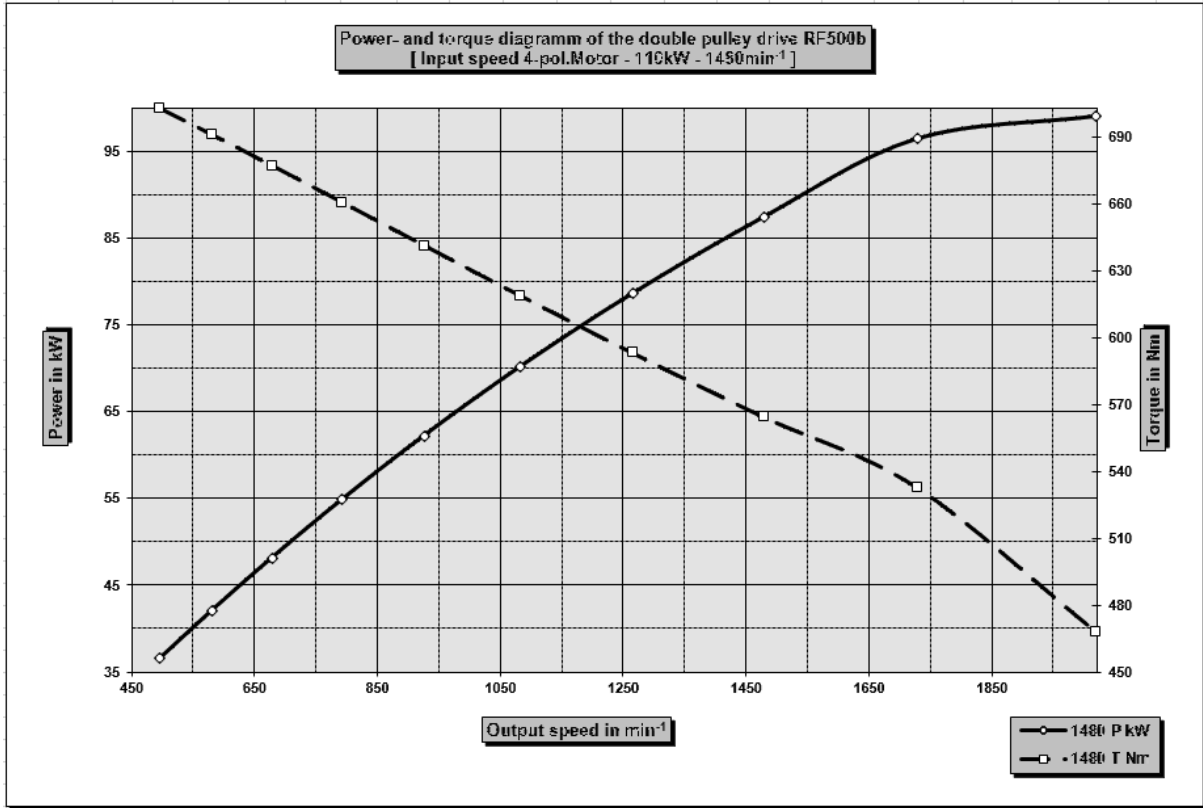

RGAE8-500 $P_1 = 90 \text{ kW}$

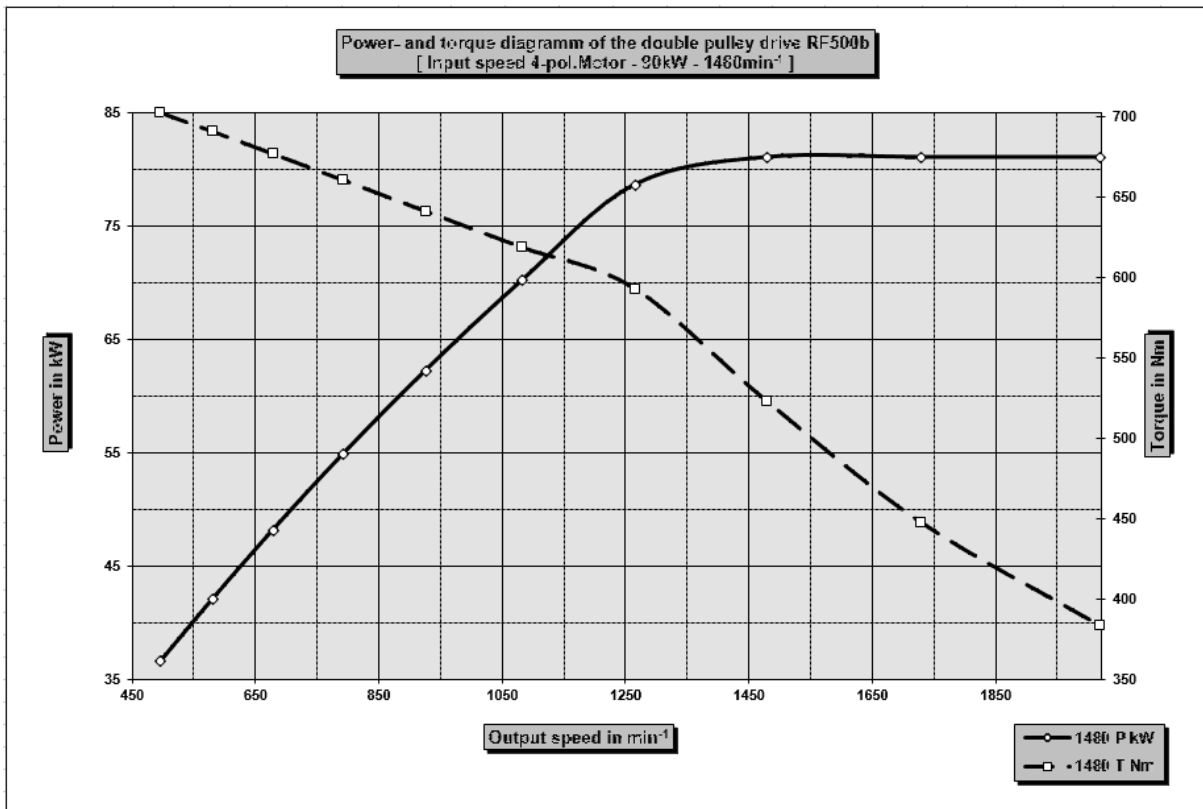

VG 9

RGAE9-600 $P_1 = 160 \text{ kW}$

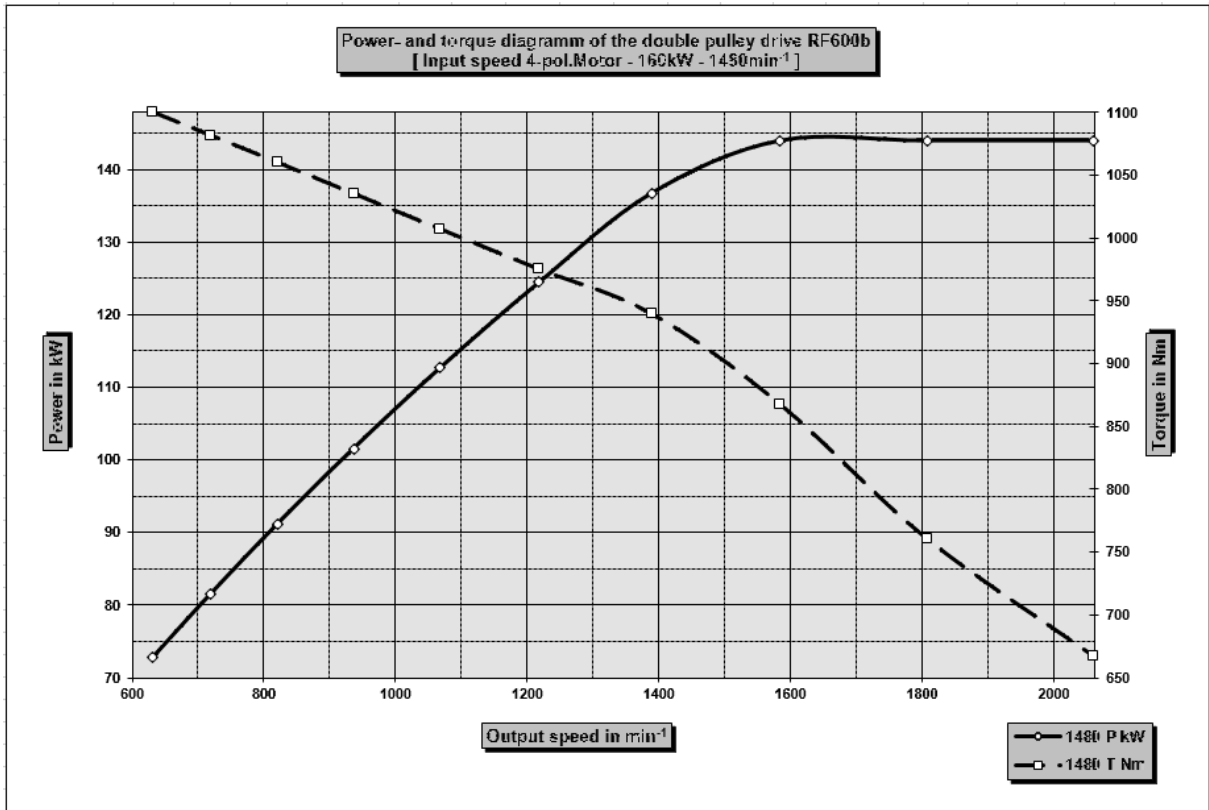

RGAE9-600 $P_1 = 132 \text{ kW}$

